

SMART Digital XL

DIGITAL DOSING from 60 to 200 l/h

DDA, DDE

Pumps and accessories



1. General data	3
Performance range	3
Features at a glance	4
2. Identification	6
3. Functions overview	7
Overview of functions	7
Functional description	8
4. Functions DDA	9
Operating elements DDA	9
Operation modes DDA	10
Functions DDA	12
Wiring diagram, DDA	17
5. Functions DDE	18
Operating elements DDE	18
Operation modes DDE	19
Functions DDE	20
Wiring diagram, DDE	21
6. Construction	22
DDA	22
DDE	23
7. Dimensions	24
8. Technical data	25
DDA	25
DDE	26
9. Pump selection	27
DDA, standard range	27
DDE, standard range	28
DDA, DDE, non-standard range	29
10. Accessories for medium-sized dosing pumps up to 460 l/h	30
Accessories overview	30
Cables and plugs	31
Hoses	32
Foot valves FV	33
Rigid suction lances RSL	34
Level-control units	37
Injection units	38
Pressure relief valves PRV	39
Pressure loading valves PLV	40
Pressure valves PV	41
Pulsation dampers and calibration columns	42
Pump connection kits and inlay kits	51
Electric stirrers	52
Withdrawal devices	54
Adapters	55
Wall or tank mounting assembly for SMART Digital XL DDA/DDE	56
Tank accessories	57
11. Pumped liquids	58
12. Grundfos Product Center	59

1. General data

Performance range

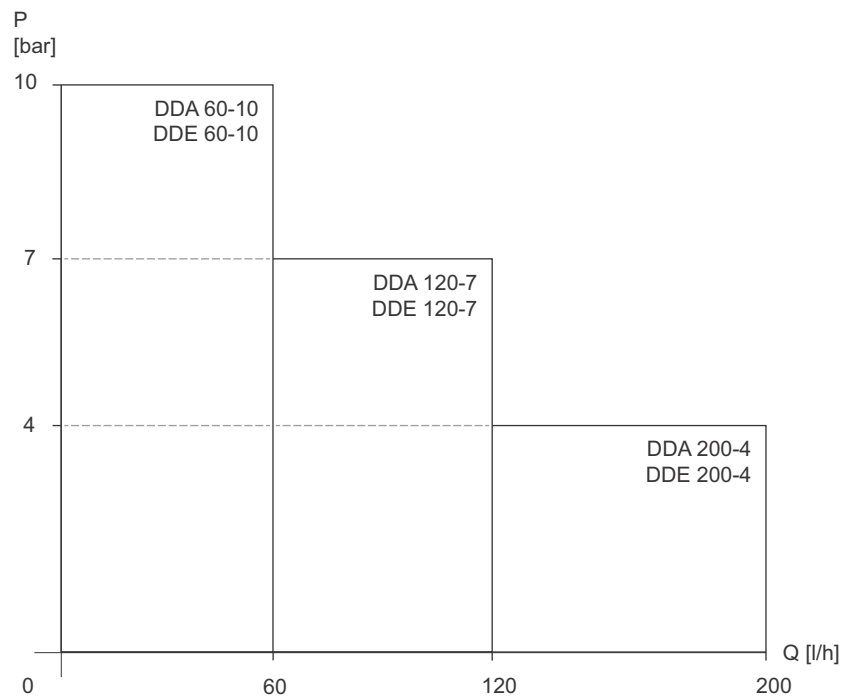

Fig. 1 Performance range

TM06 7327 3316

Features at a glance



Fig. 2 DDA, DDE

TM06 7328 3316

Digital Dosing™

The SMART Digital XL generation DDA and DDE with powerful PMS (Permanent Magnet Synchronous) motor brings state-of-the-art technology to perfection. Combined expert knowledge and the patented solutions set future standards. Traditional technologies such as stroke length or stroke frequency adjustment with asynchronous motor become a thing of the past.

Unique flexibility with only a few variants

The included mounting plate makes the pump more flexible. Service and pump exchange is easy and fast: just dismantle the pump from the mounting plate by removing two screws.

The control cube of the pump can be lifted and turned into three different positions: front, left or right.

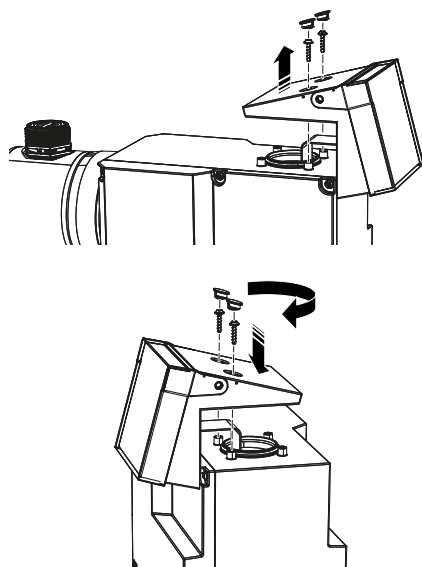

Fig. 3 Modularity of the control cube

TM06 7329 3316

A turn-down ratio of 1:800, a wide supply voltage range (100-240 V, 50/60 Hz), combined connection sets and other features reduce the models and variants to a minimum.

Precise and easy setting / usability and interaction

The operator can easily install the pump and set it to discharge exactly the quantity of dosing liquid required for the application. In the display of the DDA pump, the setting of the pump is read out directly, the flow is shown in ml/h, l/h, or gph.

The click wheel (turn-and-push knob) and the graphical LC display with plain-text menu in up to 28 languages make commissioning and operation intuitive. As the LCD is backlit in different colours, the pump status can be seen from a distance (traffic-light concept).

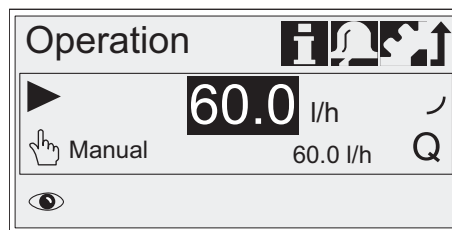

Fig. 4 Display DDA

TM06 7330 3316

Thanks to a variety of operation modes, signal inputs and outputs, the pump can easily be integrated into every process.

Advanced process reliability

An intelligent drive and microprocessor control ensures that dosing is performed precisely and with low pulsation, even if the pump is dosing high-viscosity or degassing liquids. Malfunctions, caused by air bubbles for example, are detected quickly by the maintenance-free FlowControl system and then displayed in the alarm menu.

The AutoFlowAdapt function automatically adjusts the pump according to the process conditions, such as varying backpressure. The integrated flow measurement makes additional monitoring and control equipment redundant.

Designed to save costs

In general, the investment for a dosing pump installation is low compared to its life cycle costs including the cost of the chemicals. The following features make the SMART Digital XL DDA and DDE pumps contribute to low life cycle costs:

- No underdosing or overdosing due to high dosing accuracy and FlowControl
- Longer maintenance intervals thanks to the universal chemical resistance of the double full-PTFE diaphragm
- Reduced energy consumption thanks to state-of-the-art drive technology.

Two application-oriented type ranges

DDA is the high-end pump range for extended flow and pressure ranges with sensor-based FlowControl and measurement functions for challenging industrial applications, such as:

- Drinking water treatment
- Wastewater treatment
- Boiler water treatment
- Cooling water treatment
- Process water treatment
- Chemical industry
- Ultrafiltration process and reverse osmosis
- Food and beverage industry
- Paper and pulp industry.

DDE is the economical pump range with basic functions including manual operation or control via PLC for OEM applications, such as:

- Drinking water treatment
- Wastewater treatment
- Boiler water treatment
- Cooling water treatment
- Process water treatment
- Chemical industry
- Ultrafiltration process and reverse osmosis
- Food and beverage industry
- Paper and pulp industry
- Irrigation
- Swimming pool water.

2. Identification

The type key is used to identify the precise pump and is not used for configuration purposes.

Example: **DDA 60-10 FCM-PVC/V/C-F-31U3U3FG**

Type	
DDA 60-10 FCM-PVC/V/C-F-31U3U3FG	
	DDA
	DDE
Max. flow [l/h]	
DDA 60-10 FCM-PVC/V/C-F-31U3U3FG	
Max. pressure [bar]	
DDA 60-10 FCM-PVC/V/C-F-31U3U3FG	
Control variant	
DDA 60-10 FCM -PVC/V/C-F-31U3U3FG	
B	Basic (only DDE)
AR	DDA: Alarm relay DDE: B with pulse mode, analog mode and alarm relay
FCM	AR + FlowControl function
Dosing head variant	
DDA 60-10 FCM- PVC /V/C-F-31U3U3FG	
PVC	Polyvinyl chloride
PV	PVDF
SS	Stainless steel 1.4401
PVC-L	PVC + integrated diaphragm leakage detection
PV-L	PV + integrated diaphragm leakage detection
SS-L	SS + integrated diaphragm leakage detection
Gasket material	
DDA 60-10 FCM-PVC/V/C-F-31U3U3FG	
E	EPDM
V	FKM
T	PTFE
Valve ball material	
DDA 60-10 FCM-PVC/V/C-F-31U3U3FG	
C	Ceramics
SS	Stainless steel 1.4401
Control cube	
DDA 60-10 FCM-PVC/V/C- F -31U3U3FG	
F	Front mounted (change to left or right is possible)
Supply voltage	
DDA 60-10 FCM-PVC/V/C-F-31U3U3FG	
3	100-240 V 50/60 Hz single phase
Valve type	
DDA 60-10 FCM-PVC/V/C-F-31U3U3FG	
1	Standard
2	Spring-loaded
Connection, inlet / outlet	
DDA 60-10 FCM-PVC/V/C-F-31 U3U3 FG	
U3U3	2x Union nut G 5/4" 2x Hose connector 19/20 mm 2x Hose clamp 2x Pipe connector 25 mm
A7A7	2x Union nut G 5/4" 2x Inlay external thread 3/4" NPT
A1A1	2x Union nut G 5/4" (SS) 2x Inlay internal thread Rp 3/4" (SS)

Connection, inlet / outlet	
A3A3	2x Union nut G5/4 (SS) 2x Inlay internal thread 3/4" NPT (SS)
Mains plug	
DDA 60-10 FCM-PVC/V/C-F-31U3U3FG	
F	EU (Schuko)
B	USA, Canada
G	UK
I	Australia, New Zealand, Taiwan
E	Switzerland
J	Japan
L	Argentina
Design / approval	
DDA 60-10 FCM-PVC/V/C-F-31U3U3 FG	
G	Grundfos red
A	Grundfos green
B	Grundfos black
X	Neutral / black
C	China approval
Special variant	
DDA 60-10 FCM-PVC/V/C-F-31U3U3 FGC3	
Standard	
C3	Inspection certificate 3.1 (EN 10204)

3. Functions overview

Overview of functions

	DDA		DDE	
	FCM	AR	AR	B
General				
Digital Dosing: Internal stroke speed control and frequency control	•	•	•	•
Mounting plate	•	•	•	•
Control panel, see page 9 and 18				
Control cube mountable in three positions: front, left, right	•	•	•	•
Transparent protective cover for control elements	•	•	•	•
Capacity setting in millilitres, litres or US-gallons	•	•		
Graphical display with background light in four colours for status indication: white, green, yellow, red	•	•		
LEDs for operation mode, warning and alarm			•	•
Plain-text menu in different languages	•	•		
Turn-and-push knob (click wheel) for easy navigation	•	•		
Capacity adjusting knob (0.125 - 100 %)			•	•
Start/Stop key	•	•		
100 % key (deaeration)	•	•	•	
Operation mode key (manual/pulse/analog)			•	
Operation modes, see page 10 and 19				
Manual speed control	•	•	•	•
Pulse control in ml/pulse	•	•		
Pulse control (1:n)			•	
Analog control 4-20 mA			•	
Analog control 0/4-20 mA	•	•		
Batch control (pulse-based)	•	•		
Dosing timer cycle	•	•		
Dosing timer week	•	•		
Fieldbus control	•	•		
Functions, see page 12 and 20				
Auto deaeration also during pump standby	•	•		
FlowControl system with selective fault diagnosis	•			
Pressure monitoring (min/max)	•			
Flow measurement	•			
AutoFlowAdapt	•			
SlowMode (anti-cavitation)	•	•		
Calibration mode	•	•		
Full scaling of analog input	•	•		
Scaling of maximum analog input			•	
Service information display	•	•		
Relay setting: alarm, warning, stroke signal, pump dosing, pulse input*	•	•	•	
Relay setting (additionally): timer cycle, timer week	•	•		
Inputs/outputs, see page 12 and 20				
Input for external stop	•	•	•	
Input for pulse control	•	•	•	
Input for analog 4-20 mA control			•	
Input for analog 0/4-20 mA control	•	•		
Input for low-level signal	•	•	•	
Input for empty tank signal	•	•	•	
Output relay (2 relays)	•	•	•	
Output analog 0/4-20 mA	•	•		
Input/Output for GENIbus	•	•		
Input for software update	•	•	•	•
Input/Output for CIU (Profibus DP, Modbus, GRM, Ethernet etc.)	•	•		

* DDE-AR: relay 1: alarm; relay 2: low-level signal, stroke signal, pulse input

Functional description

The electronically controlled PMS (Permanent Magnet Synchronous) motor of the DDA and DDE pumps provides optimum control of the stroke speed. The duration of each discharge stroke varies according to the capacity set, resulting in optimum dosing flow in any operating situation, while the duration of each suction stroke is constant (see figure below).

The advantages are as follows:

- The pump always operates at full stroke length, irrespective of the capacity set; this ensures optimum accuracy, priming and suction.
- A capacity range 1:800 (turn-down ratio) reduces variants and spare parts.
- Smooth and continuous dosing ensuring an optimum mixing ratio at the injection point without needing static mixers.
- Significant reduction of pressure peaks, preventing mechanical stress on wearing parts such as diaphragm, tubes, connections, resulting in extended maintenance intervals.
- The installation is less affected by long inlet and outlet lines.
- Easier dosing of high-viscosity and degassing liquids (SlowMode).

The optimum dosing control shown below takes place in any operation mode.

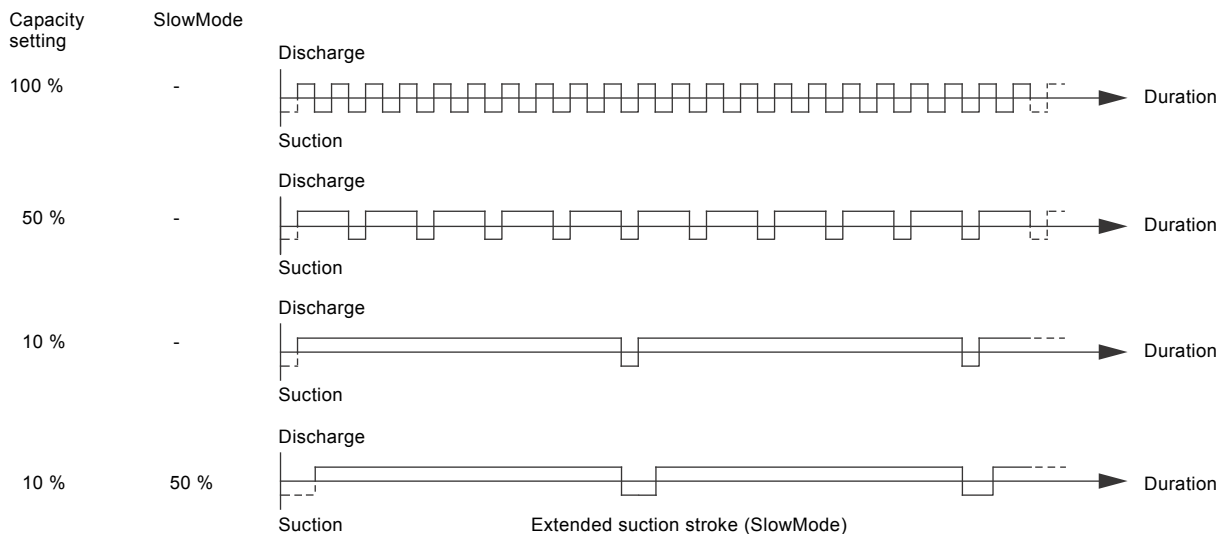

TM06 7332 33 16

Fig. 5 Relation between stroke-frequency adjustment and capacity

4. Functions DDA

Operating elements DDA

The pump is supplied with front-mounted control cube. The position of the control cube can easily be changed by unfastening two screws, lifting the cube, turning it to the left or to the right and fastening both screws again.



Fig. 6 Two of three possible control cube positions

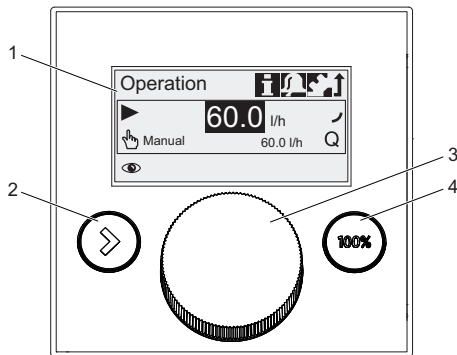

Fig. 7 Operating elements DDA

Pos.	Description
1	Graphical LC display
2	[Start/Stop] key
3	Click wheel
4	[100%] key

The click wheel guides the user quickly and easily through the plain-text menu.

If the maximum capacity is required over a short period of time, for example during startup, press the [100%] key. To set the pump to run for a specific number of seconds at maximum capacity, press the [100%] key and turn the click wheel clockwise simultaneously.

Menu

The DDA dosing pumps feature a user-friendly plain-text menu. The menu consists of 4 tabs:

- Operation
- Info
- Alarm
- Setup

During initial startup, all menu text appears in the English language. The menu can be set to display other languages.

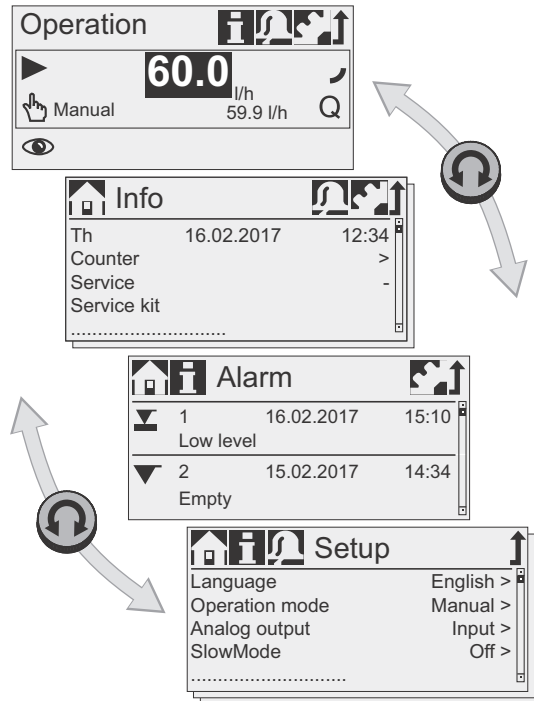

Fig. 8 Menu overview (example of main menus)

The menu text appears in up to 28 languages on a big graphical display, backlit in four different colours according to the traffic light concept.

Display	Fault	Pump status	
White	-	Stop ■	Standby
Green	-		Running ▶
Yellow	Warning	Stop ■	Standby Running ▶
Red	Alarm	Stop ■	Standby

Operation modes DDA

Manual control

In this operation mode, the pump constantly doses the dosing flow set with the click wheel. The dosing flow is set in l/h or ml/h. The pump automatically switches between the units. Alternatively, the display can be reset to US units (gph).

Setting range

Pump type	Setting range*	
	From [l/h]	To [l/h]
DDA 60-10	0.075	60
DDA 120-7	0.15	120
DDA 200-4	0.25	200

* When the SlowMode function is enabled the max. flow is reduced (see page 12)

Pulse control

In this operation mode, the pump doses the set dosing volume for each incoming (potential-free) pulse, e.g. from a water meter. There is no direct relation between pulses and dosing strokes. The pump automatically calculates the optimum stroke frequency for dosing the set volume per pulse.

The calculation is based on:

- the frequency of external pulses
- the set dosing volume/pulse.

The quantity to be dosed is set in ml/pulse.

Setting range

Pump type	Setting range [ml/pulse]
DDA 60-10	0.0111 - 111
DDA 120-7	0.0232 - 232
DDA 200-4	0.0386 - 386

The frequency of incoming pulses is multiplied by the set dosing volume. If the product exceeds the maximum flow of the pump, a maximum of 65,000 pulses can be stored for later processing with the pulse memory function, when activated.

Analog 0/4-20 mA control

In this operation mode, the pump doses according to the external analog signal. The dosing volume is proportional to the signal input value in mA.

Operation mode	Input signal [mA]	Dosing flow [%]
4-20	≤ 4.1	0
	≥ 19.8	100
0-20	≤ 0.1	0
	≥ 19.8	100

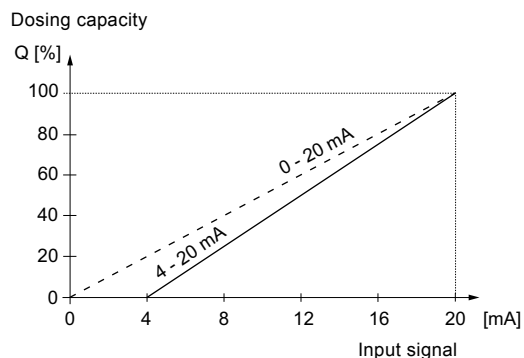

Fig. 9 0/4-20 mA control

With the analog scaling function, the curve can be individually drawn between two arbitrary points: I_1/Q_1 and I_2/Q_2 .

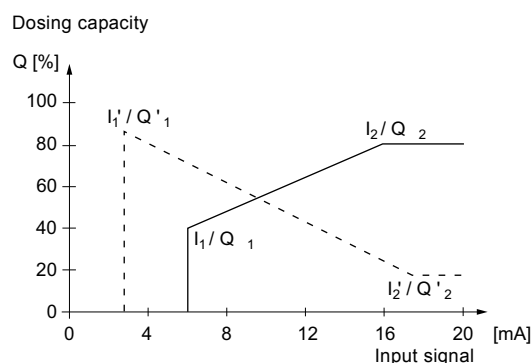
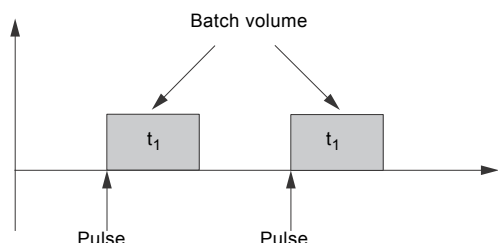

Fig. 10 Analog scaling

Pulse-based batch control



The set quantity is dosed in batches within the set dosing time (t_1). A batch is dosed every time the pump receives an external pulse. If the pump receives new pulses before a batch is completed, these pulses will be ignored. In the event of interrupts such as external stop or alarm, incoming pulses will also be ignored. After ending of the interrupts, a new batch will be dosed with the next incoming pulse.



TM04 1578 2010

Fig. 11 Pulse-based batch control

Setting range

Pump type	Setting range		
	From [ml/batch]	To [l/batch]	Resolution [ml]*
DDA 60-10	5.56	999	0.694
DDA 120-7	11.6	999	1.45
DDA 200-4	19.3	999	2.41

* Thanks to the digital motor control, dosing quantities with a resolution of up to 1/8 of the dosing stroke volume can be dosed.

Dosing timer cycle



After a start delay (t_2) the set batch volume is repeatedly dosed in the set cycle time (t_3). The dosing time (t_1) can be adjusted. Batch dosing is stopped during any interrupt, e.g. power supply failure or external stop while the time continues running in the background (real-time clock). After ending of the interrupt, batch dosing proceeds according to the current status in the timeline.

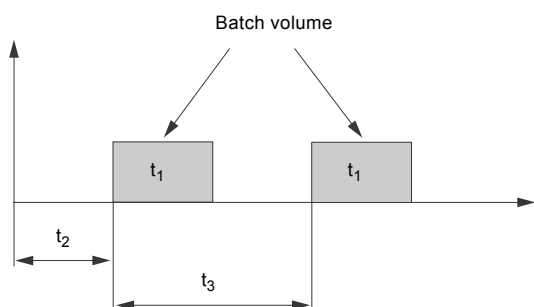

TM04 1577 1410

Fig. 12 Dosing timer cycle

Setting range

The batch volume setting range corresponds to the pulse-based batch control setting range.

Dosing timer week



The integrated real-time clock features also batch dosing based on a weekly period. There is a maximum of 16 procedures per week. Each dosing procedure consists of:

- Batch volume
- Dosing time
- Start time
- 1 to 7 weekdays (Monday to Sunday).

In case several procedures are overlapping, the procedure with the highest flow rate has the highest priority. Batch dosing is stopped during any interrupt, e.g. power supply failure or external stop, while the time continues running in the background (real-time clock). After ending of the interrupt, batch dosing proceeds according to the current status in the timeline.

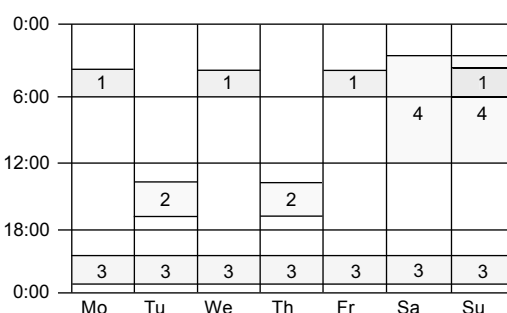

TM04 1576 1410

Fig. 13 Dosing timer week (example with 4 procedures)

Setting range

The batch volume setting range corresponds to the pulse-based batch control setting range.

Functions DDA

SlowMode



When the SlowMode function (anti-cavitation) is selected, the pump extends and smooths its suction stroke. This results in a softer suction stroke.

The SlowMode function is used in these situations:

- when pumping high-viscosity liquids
- when pumping degassing liquids
- when the inlet line is long
- when the suction lift is high.

Depending on the application, the motor speed during the suction stroke can be reduced individually to approximately 50 % or 25 % of the normal motor speed.

The maximum pump capacity is reduced accordingly. See page 25 for further details.

Auto deaeration



The auto deaeration function avoids breakdown of the dosing process due to air-locking, when dosing degassing liquids such as sodium hypochlorite. During long dosing breaks, e.g. at the weekend or overnight, air-bubbles can form in the inlet line and get into the dosing head. If too much air is in the dosing head, and the dosing process is started again, no liquid will be dosed (air-lock). Software-controlled diaphragm movements at regular intervals encourage the air bubbles to rise and finally to be displaced out of the dosing head.

These movements are executed

- when the pump is not stopped and
- during dosing breaks (e.g. external stop or no incoming pulses).

Calibration

The pump is calibrated in the factory at the nominal pressure of the respective pump type (see maximum pressure in Technical data page 25). After startup, the dosing pump can be calibrated for the actual installation to ensure that the displayed value (ml, l or gph) is correct. A calibration program in the setup menu facilitates this process. The AutoFlowAdapt function keeps the dosing precision (DDA-FCM control variant), even if the backpressure changes.

For the description of the AutoFlowAdapt function, see page 16.

External stop



With the external stop function, the pump can be stopped from a remote place via an external contact. It is not recommended to switch on and off the power supply as it was usual when working with a conventional dosing pump. When working with microprocessor-controlled digital dosing pumps, the external stop signal has to be used, in order to keep the optimal dosing precision and to prevent damages to the electronics.

When activating the external stop signal, the pump changes from running ► to standby II. The signal input can be set to normally open (default) or normally closed contact. The operation display shows an activated external stop ► II.

Counters

The pump displays resettable and non-resettable counters in the info  menu tab.

Counter	Description	Resettable
Volume	Accumulated dosed quantity in litres or US gallons	Yes
Operating hours	Accumulated number of operating hours (power-on)	No
Motor runtime	Accumulated number of motor runtime hours	No
Strokes	Accumulated number of dosing strokes	No
Power on/off	Accumulated number of times the mains supply has been switched on	No

Service display



Due to the optimised construction and the smooth digital dosing principle, the service periods are more than twice as long, if compared to conventional pumps. However, the wear parts have to be exchanged in regular intervals in order to keep the dosing precision and the process reliability at a high level. The service display in the pump shows when service of the wear parts is required. The displayed service kit product number makes service more convenient. The following information is displayed in the Info  display:

Display	Description
Service	- No service required
	Soon Order parts for service soon
	Now Service must be performed now
Service kit	8-digit Grundfos product number The service kit contains all parts needed for standard maintenance: diaphragm + valves
Reset service system	After performing the service, reset the system

The following service messages appear, depending on what happens first:

Display	Motor runtime [h]	Regular intervals [months]
Service soon	7,500	23
Service now	8,000	24

In case of difficult liquids the service intervals can be shorter and service has to be performed earlier.

Level control



The pump can be connected to a dual level control unit for monitoring of the chemical level in the tank. The pump can react to two level signals:

Level sensors	Pump reaction*
Low-level signal	<ul style="list-style-type: none"> • Display is yellow (Warning) • ▼ is flashing • Pump continues running
Empty tank signal	<ul style="list-style-type: none"> • Display is red (Alarm) • ▼ is flashing • Pump stops

* Depending on the pump model and settings, the relay outputs can be activated (see [Relay output](#), page 13)

Relay output

The pump can switch two external signals using installed relays. The relay outputs are potential-free. Depending on the process control requirements, the following relay output settings can be chosen:

Signal		Description
Relay 1	Relay 2	
Alarm*	Alarm	Display red, pump stopped (e.g. empty tank signal, etc.)
Warning*	Warning	Display yellow, pump running (low level signal, etc.)
Stroke signal	Stroke signal	Every completed stroke
Pump dosing	Pump dosing*	Pump is running and dosing
Pulse input	Pulse input	Every pulse coming in from pulse input
Bus control	Bus control	Set by a command in the Bus communication function (page 13)
	Timer cycle	Timer can be set in menu: on-time, cycle-time, start delay
	Timer week	Timer can be set in menu: procedure, on-time, start time and weekdays
Contact type		
NO*	NO*	Normally Open Contact
NC	NC	Normally Closed Contact

* default setting

Analog output

In addition to the analog input (operation mode: analog 0/4-20 mA) the pump is also equipped with an analog 0/4-20 mA output signal. Depending on the process control requirements, the following analog output settings are available:

Setting	Description of analog output signal	Control variant	
		FCM	AR
Output = Input	Analog feedback signal (not for master-slave application). The analog input signal is mapped 1:1 to the analog output.	X	X
Actual flow	Flow measured in the dosing head (Flow Measurement page 16)	X	X*
Backpressure	Backpressure measured in the dosing head (Pressure monitoring page 16)	X	
Bus control	Set by a command in the bus communication (see below)	X	X

* Output signal is calculated based on motor speed and pump status (target flow rate).

Bus communication

BUS

The pump can be connected to a Grundfos CIU unit (Communication Interface Unit) equipped with one of the following CIM modules (Communication Interface Module):

- CIM150 Profibus
- CIM200 Modbus
- CIM270 GRM
- CIM500 Ethernet

For internal communication between the CIU and the dosing pump, GENIbus is used.

Key lock



To protect the pump from maloperation, a key lock can be set by entering a 4-digit PIN-code. When the pump is locked, it is still possible to navigate through the menus Alarm and Info and to acknowledge alarms. Two levels of protection are available:

- Settings: the keys and are still available.
- Settings + keys: the keys and are also locked.

For temporary (2 minutes) or final deactivation the preset 4-digit pin-code has to be entered again.

Basic settings

The pump can be reset to the default settings. In addition the current configuration of the pump can be stored and can be activated later. The latest saved configuration is stored in the memory.

Units

It is possible to select metric units (litre/millilitre/bar) or US units (US gallons/psi). Depending on the operation mode and menu, the following units are displayed:

Operation mode/Function	Metric units	US units
Manual control	ml/h or l/h	gph
Pulse control	ml/□	ml/□
Analog 0/4-20 mA control	ml/h or l/h	gph
Batch control (pulse- or timer-based)	ml or l	gal
Calibration	ml	ml
Volume counter	l	gal
Pressure monitoring	bar	psi

Additional display

The additional display function provides further useful status information, e.g. the target flow rate as well as the actual flow rate. The value is shown in the operation display together with the corresponding symbol.

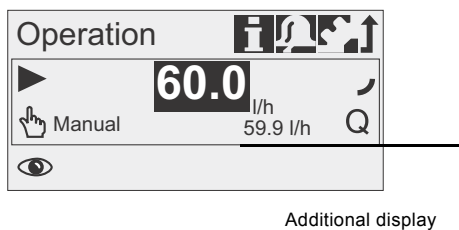

Fig. 14 Additional display

The following additional information can be selected:

Settings	Description
	Depending on the operation mode:
	Q Actual flow (manual, pulse) ¹⁾
Default display	Q Target flow (pulse)
	↻ Input current (analog)
	√ Remaining batch volume (batch, timer)
	⏱ Time until next batch (timer)
Dosed volume	V Total dosed volume (Counters see page 12)
Actual flow	Q Actually measured flow ¹⁾
Backpressure	P Current backpressure in the dosing head ¹⁾

¹⁾ Only DDA-FCM control variant

Diaphragm leakage detection (DLD)

Applies to DDA-AR control variant

Pumps with diaphragm leakage detection (DLD) have a special dosing head with a special diaphragm and a pressure switch. The pressure switch is fitted and connected to the pump on delivery.

For pumps with diaphragm leakage detection the pressure differential between inlet and outlet side must be at least 2 bar / 29 psi.

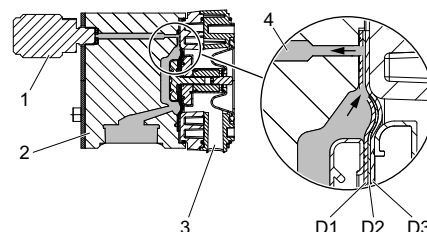

Fig. 15 Diaphragm leakage detection

Pos.	Components
1	Pressure switch
2	Dosing head
3	Drain opening
4	Dosing medium
D1	Working diaphragm
D2	Signal diaphragm (intermediate layer)
D3	Protective diaphragm

In case of a leak in the working diaphragm:

- Dosing medium (4) penetrates between working diaphragm (D1) and protective diaphragm (D3) and is transferred to the pressure switch (1) through the signal diaphragm (D2).
- On the next discharge stroke the increasing pressure activates the pressure switch (1).
- The pump indicates an alarm and stops.

The pump provides two relay outputs, which can be used to trigger an external alarm, for example.

FlowControl

Applies to DDA-FCM control variant

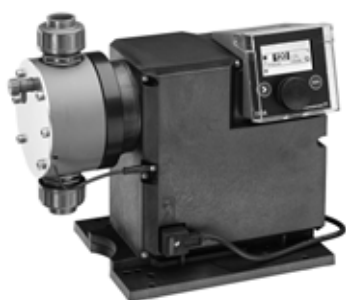

TM06 7440 3416

Fig. 16 DDA with FlowControl

The pump monitors the dosing process of liquids when the FlowControl function is activated. Although the pump is still operating, some influences such as air bubbles may cause reduced flow rates or even stop the dosing process.

For optimal process safety and reliability, the activated FlowControl function immediately detects and displays the following malfunctions:

- Overpressure
- Outlet line burst
- Air bubbles in the dosing head
- Cavitation at the inlet side
- Inlet valve leakage
- Outlet valve leakage.

The unique FlowControl is based on an intelligent and maintenance-free sensor integrated in the dosing head. During the dosing process, the sensor measures the actual pressure and sends the measured value to the microprocessor in the pump. An internal indicator diagram is generated combining the actual pressure value with the diaphragm position (stroke length). With it, the dosing process is monitored, as the different malfunctions can immediately be detected due to their specific deviations in the curve. Compressible air bubbles, for instance, will reduce the discharge phase and the stroke volume (see fig. 17).

The sensitivity and the delay of the FlowControl function can be adjusted individually.

FlowControl requires a minimum backpressure of 2 bar. For discharge quantities < 1 l/h we recommend the use of a pressure valve (PV, see page 41) on the outlet side.

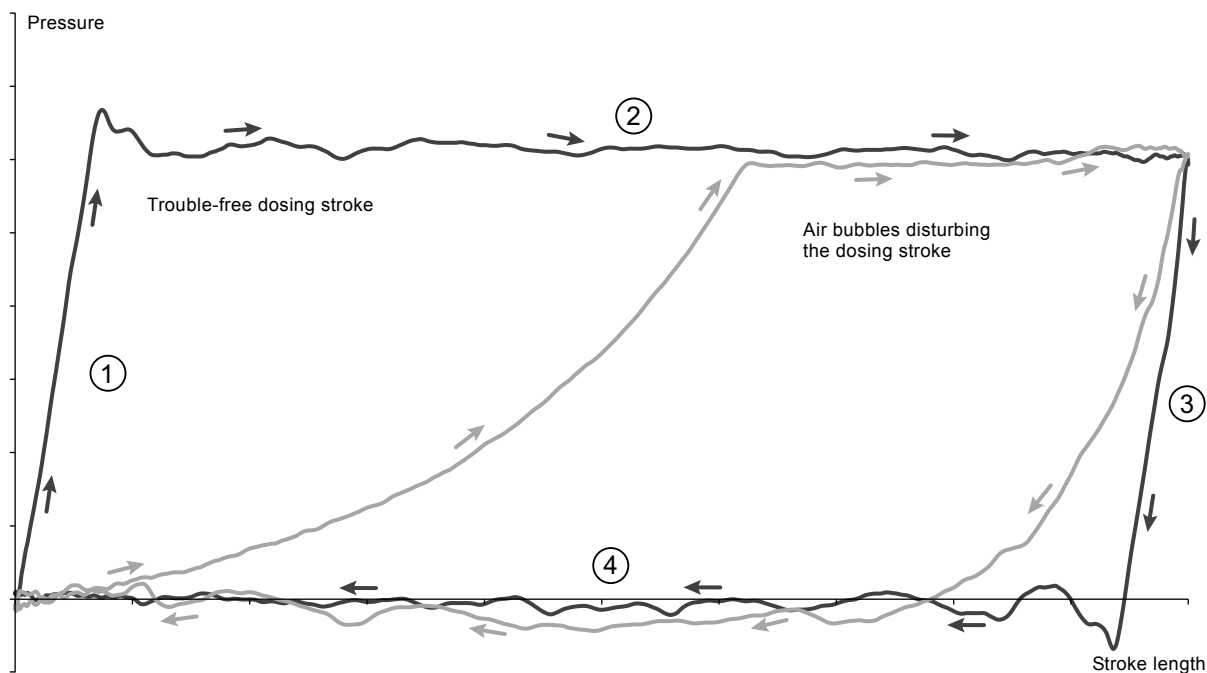

TM04 1610 1710

Fig. 17 Indicator diagram

1	Compression phase
2	Discharge phase
3	Expansion phase
4	Suction phase

Pressure monitoring

Applies to DDA-FCM control variant

The integrated pressure sensor measures the actual pressure of the system, which is shown in the display. A maximum pressure can be set. If the pressure in the system exceeds the set maximum (e.g. caused by a closed valve), the pressure monitoring function stops the dosing process immediately. As soon as the backpressure falls below the set maximum, the dosing process is continued. In case the pressure drops below the minimum limit (e.g. caused by a burst outlet line) the pump stops and major chemical spills are prevented.

Pressure setting range

Pump type	Fixed min. pressure [bar]*	Adjustable max. pressure [bar]**
DDA 60-10	< 2	3 ... 11 (default)
DDA 120-7	< 2	3 ... 8 (default)
DDA 200-4	< 2	3 ... 5 (default)

* Can be either set as a warning (pump keeps running) or as an alarm (pump stops)

** The adjustable max. pressure is equivalent to the max. operating pressure plus 1 bar

Flow measurement

Applies to DDA-FCM control variant

The pump can precisely measure and display the actual dosing flow. Via the analog 0/4-20 mA output, the actual flow signal can easily be integrated in any process control system, without needing any additional measurement equipment.

The Flow measurement function is based on an indicator diagram as described in FlowControl (page 15). Accumulating the length of each discharge stroke phase and multiplying it with the stroke frequency results in the displayed actual flow. Any malfunctions, such as air bubbles or lower backpressure, will result in a reduced or increased actual flow rate. When the AutoFlowAdapt function (page 16) is activated, the pump compensates these influences by correcting the stroke speed.

AutoFlowAdapt

Applies to DDA-FCM control variant

When activating the AutoFlowAdapt function even environmental changes will be compensated, so that the required target flow rate will be achieved. The integrated AutoFlowAdapt makes additional monitoring and control devices redundant. The AutoFlowAdapt function is based on:

- FlowControl: malfunctions are detected
- Pressure monitoring: system pressure changes are detected
- Flow measurement: deviations in the target flow are detected.

Examples:

- FlowControl detects air bubbles in the system. Due to a special motor drive strategy and a certain speed increase, the pump will try to keep the flow rate constant. This is especially important when dosing degassing liquids.
- In general, increasing system pressure reduces the stroke volume whereas falling system pressure increases the stroke volume. The AutoFlowAdapt function compensates this by automatically and continuously adapting the motor speed. Despite fluctuating system pressure, dosing accuracy is maintained.

Wiring diagram, DDA

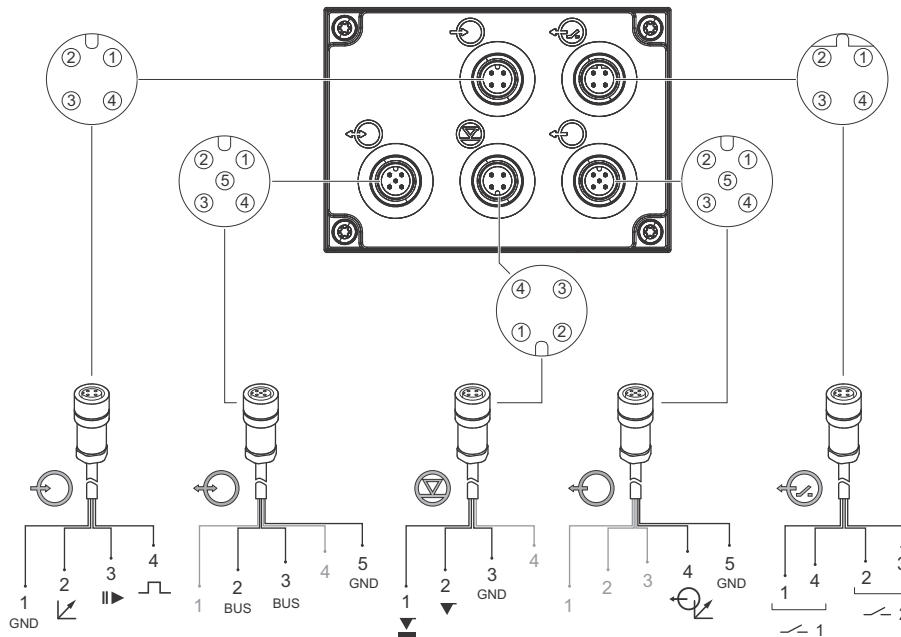

TM06 7335 3416

Symbol	Function	Pin assignment				Product number			
						2 m cable	3 m cable	5 m cable	
	Analog	1/brown	2/white	3/blue	4/black	96609014		96609016	
	External stop	GND/(-) mA		(+) mA					
	Pulse	GND			X				
	Low-level signal	X	2	3	4	see page 34, suction lances			
	Empty signal		X	GND					
	Analog output	1/brown	2/white	3/blue	4/black	5/yellow/green	96632921	96632922	
					(+) mA	GND/(-) mA			
	GENibus	1/brown	2/white	3/blue	4/black	5/yellow/green	98589048		
			RS-485 A	RS-485 B		GND			
	Relay 1	1/brown	2/white	3/blue	4/black	96609017			96609019
	Relay 2	X	X	X	X				

FlowControl signal connection

Applies to DDA-FCM control variant

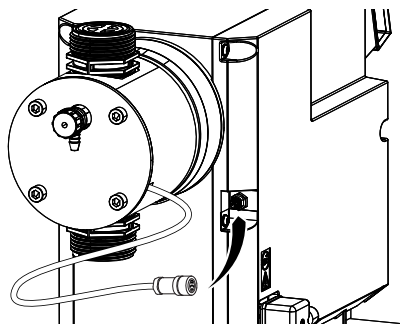

TM06 7441 2916

Fig. 18 FlowControl signal connection

DLD signal connection

Applies to DDA-AR control variant

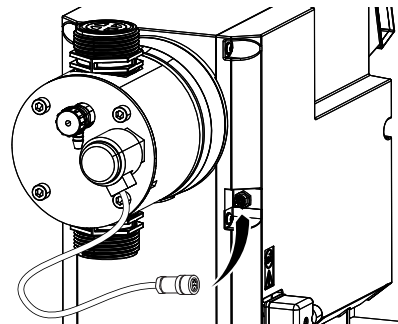

TM06 7442 2916

Fig. 19 DLD signal connection

5. Functions DDE

Operating elements DDE

The pump is supplied with front-mounted control cube. The position of the control cube can easily be changed by unfastening two screws, lifting the cube, turning it to the left or to the right and fastening both screws again.



Fig. 20 Two of three possible control cube positions

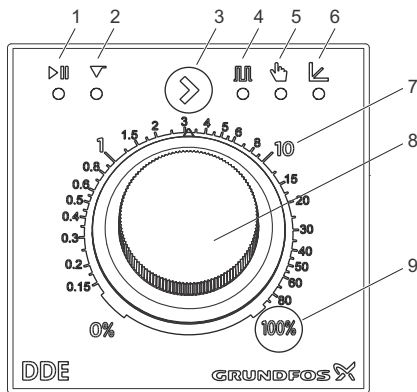

Fig. 21 Operating elements DDE

Pos.	Description	Control variant	
		B	AR
Status LEDs			
1	Motor blockage (red)	•	•
	External stop (red)		•
2	Tank level (yellow)		•
3	[Operation mode] key		•
Operation mode LEDs (green):			
4	Pulse		•
5	Manual	•	•
6	Analog	•	•
7	Logarithmic scale	•	•
8	Capacity adjusting knob	•	•
9	[100%] key		•

With the capacity adjusting knob the capacity of the pump can easily be adjusted in % of the maximum flow. Due to the logarithmic increase of the percent values, even small dosing capacities can be set accurately.

LEDs (DDE-B)

The LEDs indicate the following operating statuses and faults:

LED status		Pump status	Description
▶▶	⬅		
	•	running	
	○	standby	Capacity adjusted to 0 %
○		stop	Motor blocked or overheated

• = LED on
○ = LED flashing
Empty table cell = LED off

Keys and LEDs (DDE-AR)

When pressing and holding down the [100%] key, the pump doses at 100 % for a certain time. The [100%] key can be used e.g. for deaeration.

The [Operation mode] key is used to change the operation mode.

The operation mode LEDs indicate the active operation mode. Only one operation mode can be active at a time. Together with the status LEDs, the operation mode LEDs indicate the following statuses and faults:

LED status					Pump status	Description
▶▶	▼	▶▶	⬅	⬅		
			•		running	
			○		standby	Capacity adjusted to 0 %
		•			running	
		○			standby	No incoming pulses
			•		running	
			○		standby	Analog signal < 4.1 mA
	○		•		running	Low-level in tank
	•		○		stop	Tank empty
•			○		standby	External stop activated
○					stop	Motor blocked or overheated

• = LED on
○ = LED flashing
Empty table cell = LED off

Operation modes DDE

Manual control



In this operation mode, the pump doses constantly the dosing quantity set by the adjusting knob.

The setting range depends on the pump type:

Setting range

Pump type	Setting range	
	From [l/h]	To [l/h]
DDE 60-10	0.075	60
DDE 120-7	0.15	120
DDE 200-4	0.25	200

Pulse control



Applies to DDE-AR control variant.

In this operation mode, the pump doses the set dosing volume for each incoming (potential-free) pulse, e.g. from a water meter. The pump automatically calculates the optimum stroke frequency for dosing the set volume per pulse.

The calculation is based on:

- the frequency of external pulses
- the set stroke volume in percent.

The dosing quantity per pulse is set to a value between 0.125 % and 100 % of the stroke volume using the adjusting knob.

Setting range

Pump type	Setting range [ml/pulse]
DDE 60-10	0.0070 - 5.56
DDE 120-7	0.0145 - 11.58
DDE 200-4	0.0242 - 19.3

The frequency of incoming pulses is multiplied by the set dosing volume. If the pump receives more pulses than it can process at the maximum dosing flow, it runs at the maximum stroke frequency in continuous operation. Excess pulses will be ignored.

Analog 4-20 mA control



Applies to DDE-AR control variant.

In this operation mode, the pump doses according to the external analog signal. The dosing volume is proportional to the signal input value in mA. The input signal must be 4-20 mA.

The maximum dosing volume can be changed via the capacity adjusting knob.

Example:

Set capacity [%]	Input signal [mA]	Dosing flow [%]
100	≤ 4.1	0
	≥ 19.8	100
50	≤ 4.1	0
	≥ 19.8	50
1	≤ 4.1	0
	≥ 19.8	1

Functions DDE

External stop



Applies to DDE-AR control variant

With the external stop function, the pump can be stopped from a remote place via an external contact. It is not recommended to switch on and off the power supply as it was usual when working with a conventional dosing pump. When working with microprocessor-controlled digital dosing pumps, the external stop signal has to be used, in order to keep the optimal dosing precision and to prevent damages to the electronics.

When activating the external stop signal, the pump changes from running ► to standby ||. The signal input can be set to normally open (default) or normally closed contact.

An activated external stop is indicated by the respective LED. See [Keys and LEDs \(DDE-AR\)](#) on page 18.

Level control



Applies to DDE-AR control variant

The pump can be connected to a dual level control unit for monitoring of the chemical level in the tank. The pump can react to two level signals:

Level sensors	Pump reaction*
Low-level signal	<ul style="list-style-type: none"> ∇ LED flashes Pump continues running
Empty tank signal	<ul style="list-style-type: none"> ∇ LED on Pump stops

* Depending on the pump model and settings, the relay outputs can be activated (see [Relay output](#), page 20).

Relay output

Applies to DDE-AR control variant

The pump can switch two external signals using installed relays. The relay outputs are potential-free. Depending on the process control requirements, the following relay output settings can be chosen:

Signal		
Relay 1	Relay 2	Description
Alarm*		Empty tank, motor blocked
	Low level*	Low level tank
	Stroke signal	Every completed stroke
	Pulse input	Every pulse coming in from pulse input
Contact type		
NO*	NO*	Normally Open Contact
NC	NC	Normally Closed Contact

* default setting

Wiring diagram, DDE

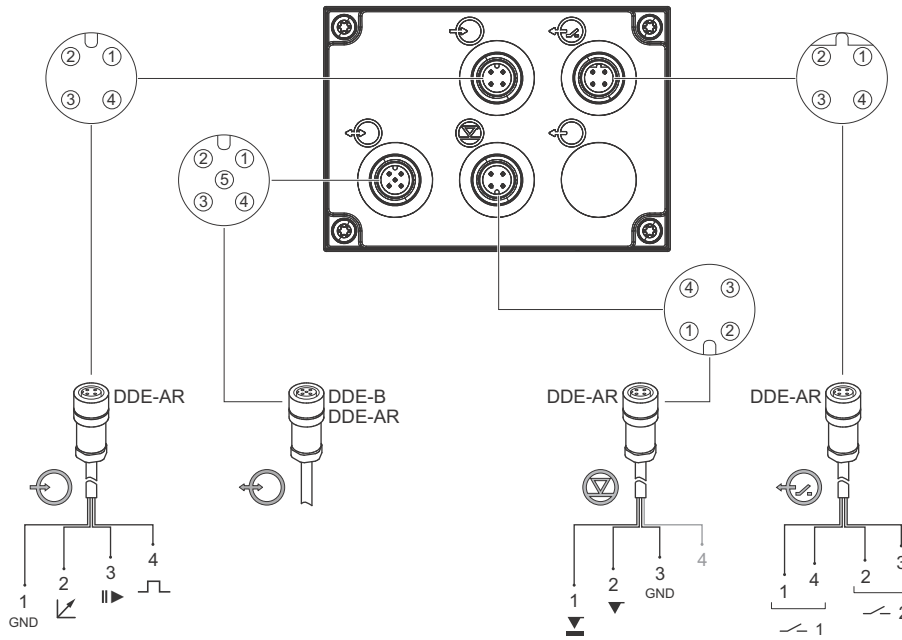

TM06 7443 3416

Symbol	Function	Pin assignment				Product number	
						2 m cable	5 m cable
	Analog	1/brown	2/white	3/blue	4/black	96609014	96609016
	External stop	GND/(-) mA		(+) mA	X		
	Pulse	GND		X	X		
	Low-level signal	1	2	3	4	see page 34, suction lances	
	Empty signal	X	X	GND	GND		
	Service connection (only for Grundfos service)						
		1/brown	2/white	3/blue	4/black	96609017	96609019
	Relay 1	X	X	X	X		
	Relay 2	X	X	X	X		

6. Construction

DDA

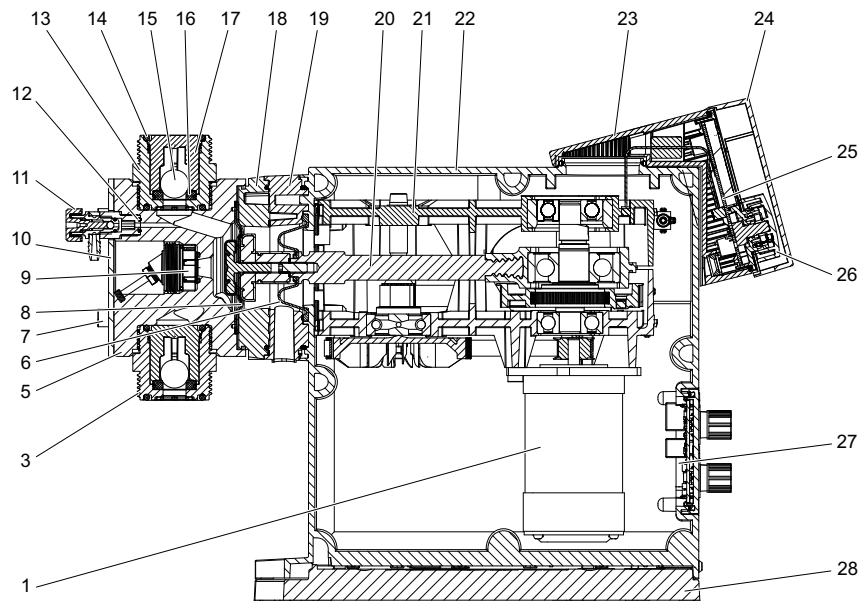

Fig. 22 Sectional drawing, DDA 60-10

TM06 7581 0617

Construction

The DDA pumps are motor-driven diaphragm dosing pumps consisting of the following main parts:

Dosing head: Patented design with a minimum of clearance space optimised for degassing liquids. With integrated deaeration valve for priming and venting complete with connection for a DN 20 tubing.

DDA-FCM pumps have an integrated pressure sensor in the dosing head.

Valves: Outlet and inlet valve design for less clearance space - optimised for degassing liquids. Spring-loaded valves for higher viscosities are available as an option.

Connections: Robust and easy-to-use connection packages for various sizes of hoses or pipes.

Diaphragm: Double full-PTFE diaphragm designed for long life and universal chemical resistance.

Flange: With separation chamber, safety diaphragm and drain hole.

Drive unit: Positive return crank with double-stage belt drive, energy recovery spring for high efficiency (only 120-7 and 200-4 pump versions), PMS motor, all mounted in a robust gear housing.

Control cube: Containing operation electronics with display, keys, click-wheel and protective cover.

Housing: Containing drive unit and power electronics with robust signal sockets. The housing can be installed on the mounting plate with two screws.

Material specification

Pos.	Description	Material options
1	PMS motor	-
3	Inlet valve, complete*	-
5	Dosing head	PVC, PVDF, SS 1.4435
6	Safety diaphragm	EPDM
7	Dosing head screw	SS 1.4301
8	Diaphragm	full PTFE
9	Pressure sensor	-
10	Dosing head cover	SS 1.4301
11	Deaeration valve	PVC, PVDF
12	Deaeration valve O-ring	EPDM/FKM
13	Outlet valve, complete*	-
14	Outlet valve O-ring	EPDM, FKM, PTFE
15	Outlet valve ball, DN 20	Ceramic Al ₂ O ₃ 99.5 %, SS 1.4401
16	Outlet valve seat	EPDM, FKM, PTFE
17	Outlet valve housing and ball cage	PP, PVC, PVDF, SS 1.4435
18	Intermediate ring	PPO/PS 20 % gf
19	Pump head flange	Aluminium alloy 3.1645
20	Connecting rod	1.4401
21	Gear box	PPE/PA 30 % gf
22	Housing	PPE/PS 20 % gf
23	Control cube	PPE/PS 20 % gf
24	Display cover	PC
25	HMI PCB	-
26	Click wheel	PPE/PS 20 % gf
27	Input/output PCB	-
28	Mounting plate	PPE/PS 20 % gf
-	Energy recovery spring	Spring steel EN 10270-1-SH

* Pump can be supplied with spring-loaded valves (Material: 2.4610 (Alloy C-4))

DDE

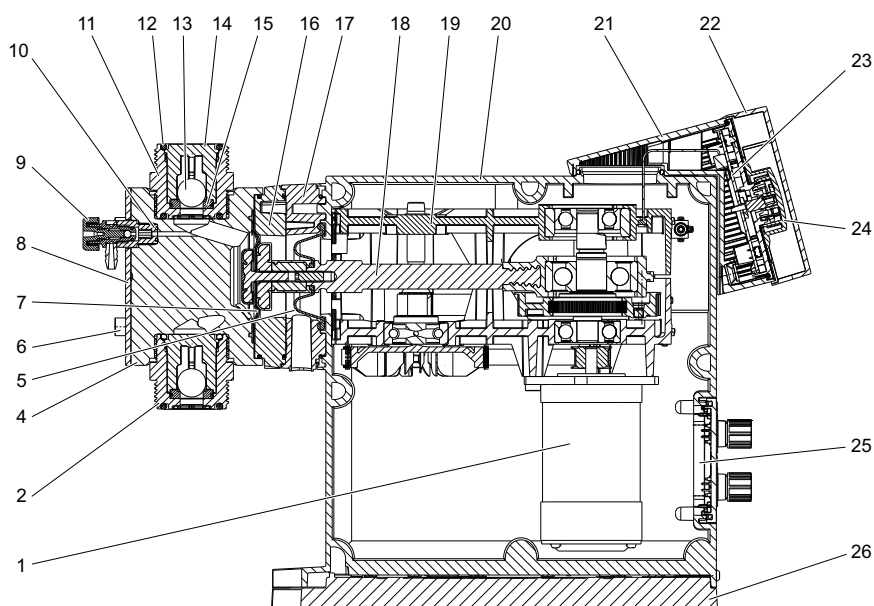

TM06 7585 0617

Fig. 23 Sectional drawing, DDE 60-10

Construction

The DDE pump is a motor-driven diaphragm dosing pump consisting of the following main parts:

Dosing head: Patented design with a minimum of clearance space optimised for degassing liquids. With integrated deaeration valve for priming and venting complete with connection for a DN 20 tubing.

Valves: Outlet and inlet valve design for less clearance space - optimised for degassing liquids. Spring-loaded valves for higher viscosities are available as an option.

Connections: Robust and easy-to-use connection packages for various sizes of hoses or pipes.

Diaphragm: Double full-PTFE diaphragm designed for long life and universal chemical resistance.

Flange: With separation chamber, safety diaphragm and drain hole.

Drive unit: Positive return crank with double-stage belt drive, energy recovery spring for high efficiency (only 120-7 and 200-4 pump versions), PMS motor, all mounted in a robust gear housing.

Control cube: Containing keys, LEDs, capacity adjusting knob and protective cover.

Housing: Containing drive unit, control panel and electronics with robust signal sockets. The housing can be installed on the mounting plate with two screws.

Material specification

Pos.	Description	Material options
1	PMS motor	-
2	Inlet valve, complete*	-
4	Dosing head	PVC, PVDF, SS 1.4435
5	Safety diaphragm	EPDM
6	Dosing head screw	SS 1.4301
7	Diaphragm	full PTFE
8	Dosing head cover	SS 1.4301
9	Deaeration valve	PVC, PVDF
10	Deaeration valve O-ring	EPDM/FKM
11	Outlet valve, complete*	-
12	Outlet valve O-ring	EPDM, FKM, PTFE
13	Outlet valve ball, DN 20	Ceramic Al ₂ O ₃ 99.5 %, SS 1.4401
14	Outlet valve housing and ball cage	PP, PVC, PVDF, SS 1.4435
15	Outlet valve seat	EPDM, FKM, PTFE
16	Intermediate ring	PPO/PS 20 % gf
17	Pump head flange	Aluminium alloy 3.1645
18	Connecting rod	1.4401
19	Gear box	PPE/PA 30 % gf
20	Housing	PPE/PS 20 % gf
21	Control cube	PPE/PS 20 % gf
22	Display cover	PC
23	HMI PCB	-
24	Capacity adjusting knob	PPE/PS 20 % gf
25	Input/output PCB	-
26	Mounting plate	PPE/PS 20 % gf
-	Energy recovery spring	Spring steel EN 10270-1-SH

* Pump can be supplied with spring-loaded valves (Material: 2.4610 (Alloy C-4))

7. Dimensions

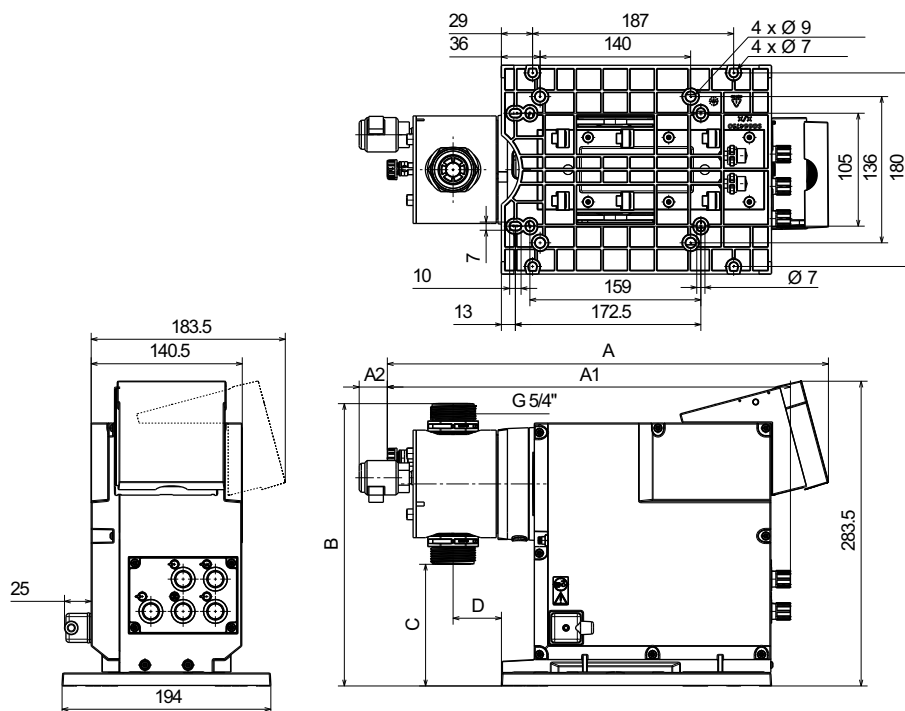

Fig. 24 DDA and DDE with front-fitted or side-fitted control cube

TM06 7444 3416

Pump type	Pump head material	A [mm]	A1 [mm]	A2* [mm]	B [mm]	C [mm]	D [mm]
DDA 60-10	PVC/PV	410	374	26	263	112	45
DDE 60-10	SS	405	364	-	263	112	45
DDA 120-7	PVC/PV	410	374	26	276.5	97	45
DDE 120-7	SS	405	364	-	276.5	97	45
DDA 200-4	PVC/PV	410	374	26	287.5	88	45
DDE 200-4	SS	405	364	-	287.5	88	45

* Dimension with optional diaphragm leakage detection. Only available for DDA-AR control variant.

8. Technical data

DDA

Data		60-10	120-7	200-4	
	Turn-down ratio (setting range)	[1:X]	800	800	800
	Max. dosing capacity	[l/h]	60	120	200
		[gph]	15.8	32	52.8
	Max. dosing capacity with SlowMode 50 %	[l/h]	30	60	100
		[gph]	7.9	16	26.4
	Max. dosing capacity with SlowMode 25 %	[l/h]	15	30	50
		[gph]	3.95	8	13.2
	Min. dosing capacity	[l/h]	0.075	0.15	0.25
		[gph]	0.0197	0.04	0.066
	Max. operating pressure (backpressure)	[bar]	10	7	4
		[psi]	145	101	58
	Max. stroke frequency ¹⁾	[strokes/min]	198	190	190
	Stroke volume	[ml]	5.56	11.58	19.3
	Accuracy of repeatability ⁵⁾	[%]	1.5 SP + 0.1 FS ⁵⁾		
Max. suction lift during operation ²⁾	[m]	3			
Mechanical data	Max. suction lift when priming with wet valves ²⁾	[m]	1.5		
		[bar]	1 ⁶⁾		
	Min. pressure difference between inlet and outlet side	[bar]	2		
		[psi]	14.5 ⁶⁾		
	Max. inlet pressure, inlet side	[bar]	2		
		[psi]	29		
	Max. viscosity in SlowMode 25 % with spring-loaded valves ³⁾	[mPas] (= cP)	3000	3000	2000
	Max. viscosity in SlowMode 50 % with spring-loaded valves ³⁾	[mPas] (= cP)	2000	1500	1000
	Max. viscosity without SlowMode with spring-loaded valves ³⁾	[mPas] (= cP)	1000	1000	500
	Max. viscosity without spring-loaded valves ³⁾	[mPas] (= cP)	100		
	Min. internal hose/pipe diameter inlet/outlet side ^{2), 4)}	[mm]	19		
	Min. internal hose/pipe diameter inlet/outlet side (high viscosity) ⁴⁾	[mm]	19		
	Min. / Max. liquid temperature (PVDF, SS)	[°C]	0/50		
	Min. / Max. liquid temperature (PVC)	[°C]	0/40		
Min. / Max. ambient temperature	[°C]	0/45			
Min. / Max. storage temperature (PVDF, SS)	[°C]	-20/70			
Min. / Max. storage temperature (PVC)	[°C]	-20/45			
Max. relative humidity (non-condensing)	[%]	90			
Max. altitude above sea level	[m]	2000			
Electrical data	Voltage	[V]	100-240 V ± 10 %, 50/60 Hz		
	Length of mains cable	[m]	1.5		
	Max. inrush current for 2 ms (100 V)	[A]	35		
	Max. inrush current for 2 ms (240 V)	[A]	70		
	Max. power consumption P ₁	[W]	62		
	Enclosure class		IP65, Nema 4X		
	Electrical safety class		I		
Pollution degree		2			
Signal input	Max. load for level input, pulse input and External stop input		12 V, 5 mA		
	Min. pulse length	[ms]	5		
	Max. pulse frequency	[Hz]	100		
	Impedance at 0/4-20 mA analog input	[Ω]	15		
	Accuracy of analog input (full-scale value)	[%]	± 0.5		
	Min. resolution of analog input	[mA]	0.02		
Signal output	Max. loop resistance in external circuit	[Ω]	150		
	Max. resistive load on relay output	[A]	0.5		
	Max. voltage on relay/analog output	[V]	30 VDC / 30 VAC		
	Max. loop resistance in external circuit of the 0/4-20 mA analog output	[Ω]	500		
	Accuracy of analog output (full-scale value)	[%]	± 0.5		
Weight/size	Min. resolution of analog output	[mA]	0.02		
	Weight (PVC, PVDF)	[kg]	6.7	7.9	8.9
	Weight (stainless steel)	[kg]	7.2	8.3	9.1
Sound pressure	Diaphragm diameter	[mm]	74	97	117
	Max. sound pressure level	[dB(A)]	80		
Approvals		CE, CSA-US, NSF61, EAC, ACS, RCM			

¹⁾ The maximum stroke frequency varies depending on calibration

²⁾ Data is based on measurements with water

³⁾ Maximum suction lift: 1 m, dosing capacity reduced (approx. 30 %)

⁴⁾ Length of inlet line: 1.5 m, length of outlet line: 10 m (at max. viscosity)

⁵⁾ FS = Full-scale (maximum actual dosing flow), SP = Setpoint

⁶⁾ For FCM control variant and for pumps with diaphragm leakage detection the pressure difference must be at least 2 bar / 29 psi.

DDE

Data		60-10	120-7	200-4	
	Turn-down ratio (setting range)	[1:X]	800	800	800
	Max. dosing capacity	[l/h]	60	120	200
		[gph]	15.8	32	52.8
	Min. dosing capacity	[l/h]	0.075	0.15	0.25
		[gph]	0.0197	0.04	0.066
	Max. operating pressure	[bar]	10	7	4
		[psi]	145	101	58
	Max. stroke frequency	[strokes/min]	198	190	190
	Stroke volume	[ml]	5.56	11.58	19.3
	Accuracy of repeatability ⁴⁾	[%]	5 SP + 0.1 FS		
Max. suction lift during operation ¹⁾	[m]	3			
Mechanical data	Max. suction lift when priming with wet valves ¹⁾	[m]	1.5		
		[bar]	1		
	Min. pressure difference between inlet and outlet side	[psi]	14.5		
		[bar]	2		
	Max. inlet pressure, inlet side	[psi]	29		
		[mPas] (= cP)	1000	1000	500
	Max. viscosity with spring-loaded valves ²⁾	[mPas] (= cP)	100		
	Min. internal hose/pipe diameter inlet/outlet side ^{1), 3)}	[mm]	19		
	Min. internal hose/pipe diameter inlet/outlet side (high viscosity) ³⁾	[mm]	19		
	Min. / Max. liquid temperature (PVDF, SS)	[°C]	0/50		
Min. / Max. liquid temperature (PVC)	[°C]	0/40			
Min. / Max. ambient temperature	[°C]	0/45			
Min. / Max. storage temperature (PVDF, SS)	[°C]	-20/70			
Min. / Max. storage temperature (PVC)	[°C]	-20/45			
Max. relative humidity (non-condensing)	[%]	90			
Max. altitude above sea level	[m]	2000			
Electrical data	Voltage	[V]	100-240 V ± 10 %, 50/60 Hz		
	Length of mains cable	[m]	1.5		
	Max. inrush current for 2 ms (100 V)	[A]	35		
	Max. inrush current for 2 ms (240 V)	[A]	70		
	Max. power consumption P ₁	[W]	62		
	Enclosure class		IP65, Nema 4X		
	Electrical safety class		I		
Pollution degree		2			
Signal input	Max. load for level input, pulse input and External stop input		12 V, 5 mA		
	Min. pulse length	[ms]	5		
	Max. pulse frequency	[Hz]	100		
	Max. loop resistance in external circuit	[Ω]	150		
	Impedance at 4-20 mA analog input	[Ω]	15		
	Accuracy of analog input (full-scale value)	[%]	± 0.5		
Min. resolution of analog input	[mA]	0.02			
Signal output	Max. resistive load on relay output	[A]	0.5		
	Max. voltage on relay output	[V]	30 VDC / 30 VAC		
Weight/size	Weight (PVC, PVDF)	[kg]	6.7	7.9	8.9
	Weight (stainless steel)	[kg]	7.2	8.3	9.1
	Diaphragm diameter	[mm]	74	97	117
Sound pressure	Max. sound pressure level	[dB(A)]	80		
Approvals		CE, CSA-US, NSF61, EAC, ACS, RCM			

¹⁾ Data is based on measurements with water

²⁾ Maximum suction lift: 1 m, dosing capacity reduced (approx. 30 %)

³⁾ Length of inlet line: 1.5 m, length of outlet line: 10 m (at max. viscosity)

⁴⁾ FS = Full-scale, SP = Setpoint

9. Pump selection

General recommendations for installation

- Installing a filter in the inlet line protects the entire installation against dirt and reduces the risk of leakage.
- A pressure relief valve (PRV, see page 39) must be installed in the outlet line to provide protection against impermissibly high pressure.
- For pipe installations and for hose installations where the pump is operated with $\geq 75\%$ of its dosing capacity, a pulsation damper (DB/DBG, see page 42) should be installed downstream the pump.
- Only for control variant DDA-FCM: For discharge quantities < 1 l/h we recommend using a pressure valve (PV, see page 41) on the outlet side for the safe generation of the necessary differential pressure (2 bar).

DDA, standard range

Supply voltage:	100-240 V, 50/60 Hz single phase
Mains plug:	EU (Schuko)
Valves:	Standard
Connection sets:	2x union nut G 5/4", 2x hose connector 19/20 mm, 2x hose clamp, 2x pipe connector 25 mm 2x union nut G 5/4" (SS), 2x inlay internal thread Rp 3/4" (SS)

Max. dosing capacity [l/h]	Max. operating pressure [bar]	Control variant	Materials			Type designation	Product number			
			Pump head	Gaskets	Valve balls					
60	10	AR	PVC	EPDM	Ceramic	DDA 60-10 AR-PVC/E/C-F-31U3U3FG	99159370			
				FKM	Ceramic	DDA 60-10 AR-PVC/V/C-F-31U3U3FG	99159371			
			PVDF	EPDM	Ceramic	DDA 60-10 AR-PV/E/C-F-31U3U3FG	99159372			
				PTFE	Ceramic	DDA 60-10 AR-PV/T/C-F-31U3U3FG	99159373			
				FKM	Ceramic	DDA 60-10 AR-PV/V/C-F-31U3U3FG	99159374			
				FKM	SS	DDA 60-10 AR-SS/V/SS-F-31A1A1FG	99159375			
			SS	PTFE	SS	DDA 60-10 AR-SS/T/SS-F-31A1A1FG	99159376			
				PTFE	SS	DDA 60-10 AR-SS/T/SS-F-31A1A1FG	99159376			
			60	10	FCM	PVC	EPDM	Ceramic	DDA 60-10 FCM-PVC/E/C-F-31U3U3FG	99159377
							FKM	Ceramic	DDA 60-10 FCM-PVC/V/C-F-31U3U3FG	99159378
PVDF	EPDM	Ceramic				DDA 60-10 FCM-PV/E/C-F-31U3U3FG	99159379			
	PTFE	Ceramic				DDA 60-10 FCM-PV/T/C-F-31U3U3FG	99159380			
	FKM	Ceramic				DDA 60-10 FCM-PV/V/C-F-31U3U3FG	99159381			
	FKM	SS				DDA 60-10 FCM-SS/V/SS-F-31A1A1FG	99159382			
SS	PTFE	SS				DDA 60-10 FCM-SS/T/SS-F-31A1A1FG	99159383			
	PTFE	SS				DDA 60-10 FCM-SS/T/SS-F-31A1A1FG	99159383			
120	7	AR				PVC	EPDM	Ceramic	DDA 120-7 AR-PVC/E/C-F-31U3U3FG	99159384
							FKM	Ceramic	DDA 120-7 AR-PVC/V/C-F-31U3U3FG	99159385
			PVDF	EPDM	Ceramic	DDA 120-7 AR-PV/E/C-F-31U3U3FG	99159386			
				PTFE	Ceramic	DDA 120-7 AR-PV/T/C-F-31U3U3FG	99159387			
				FKM	Ceramic	DDA 120-7 AR-PV/V/C-F-31U3U3FG	99159388			
				FKM	SS	DDA 120-7 AR-SS/V/SS-F-31A1A1FG	99159389			
			SS	PTFE	SS	DDA 120-7 AR-SS/T/SS-F-31A1A1FG	99159390			
				PTFE	SS	DDA 120-7 AR-SS/T/SS-F-31A1A1FG	99159390			
			120	7	FCM	PVC	EPDM	Ceramic	DDA 120-7 FCM-PVC/E/C-F-31U3U3FG	99159391
							FKM	Ceramic	DDA 120-7 FCM-PVC/V/C-F-31U3U3FG	99159392
PVDF	EPDM	Ceramic				DDA 120-7 FCM-PV/E/C-F-31U3U3FG	99159393			
	PTFE	Ceramic				DDA 120-7 FCM-PV/T/C-F-31U3U3FG	99159394			
	FKM	Ceramic				DDA 120-7 FCM-PV/V/C-F-31U3U3FG	99159395			
	FKM	SS				DDA 120-7 FCM-SS/V/SS-F-31A1A1FG	99159396			
SS	PTFE	SS				DDA 120-7 FCM-SS/T/SS-F-31A1A1FG	99159397			
	PTFE	SS				DDA 120-7 FCM-SS/T/SS-F-31A1A1FG	99159397			
200	4	AR				PVC	EPDM	Ceramic	DDA 200-4 AR-PVC/E/C-F-31U3U3FG	99159398
							FKM	Ceramic	DDA 200-4 AR-PVC/V/C-F-31U3U3FG	99159399
			PVDF	EPDM	Ceramic	DDA 200-4 AR-PV/E/C-F-31U3U3FG	99159400			
				PTFE	Ceramic	DDA 200-4 AR-PV/T/C-F-31U3U3FG	99159401			
				FKM	Ceramic	DDA 200-4 AR-PV/V/C-F-31U3U3FG	99159402			
				FKM	SS	DDA 200-4 AR-SS/V/SS-F-31A1A1FG	99159403			
			SS	PTFE	SS	DDA 200-4 AR-SS/T/SS-F-31A1A1FG	99159404			
				PTFE	SS	DDA 200-4 AR-SS/T/SS-F-31A1A1FG	99159404			
			200	4	FCM	PVC	EPDM	Ceramic	DDA 200-4 FCM-PVC/E/C-F-31U3U3FG	99159405
							FKM	Ceramic	DDA 200-4 FCM-PVC/V/C-F-31U3U3FG	99159406
PVDF	EPDM	Ceramic				DDA 200-4 FCM-PV/E/C-F-31U3U3FG	99159407			
	PTFE	Ceramic				DDA 200-4 FCM-PV/T/C-F-31U3U3FG	99159408			
	FKM	Ceramic				DDA 200-4 FCM-PV/V/C-F-31U3U3FG	99159409			
	FKM	SS				DDA 200-4 FCM-SS/V/SS-F-31A1A1FG	99159410			
SS	PTFE	SS				DDA 200-4 FCM-SS/T/SS-F-31A1A1FG	99159411			
	PTFE	SS				DDA 200-4 FCM-SS/T/SS-F-31A1A1FG	99159411			

DDE, standard range

Supply voltage:	100-240 V, 50/60 Hz single phase
Mains plug:	EU (Schuko)
Valves:	Standard
Connection sets:	2x union nut G 5/4", 2x hose connector 19/20 mm, 2x hose clamp, 2x pipe connector 25 mm 2x union nut G 5/4" (SS), 2x inlay internal thread Rp 3/4" (SS)

Max. dosing capacity [l/h]	Max. operating pressure [bar]	Control variant	Materials			Type designation	Product number
			Pump head	Gaskets	Valve balls		
60	10	B	PVC	EPDM	Ceramic	DDE 60-10 B-PVC/E/C-F-31U3U3FG	99159328
				FKM	Ceramic	DDE 60-10 B-PVC/V/C-F-31U3U3FG	99159329
			PVDF	EPDM	Ceramic	DDE 60-10 B-PV/E/C-F-31U3U3FG	99159330
				PTFE	Ceramic	DDE 60-10 B-PV/T/C-F-31U3U3FG	99159331
			SS	FKM	Ceramic	DDE 60-10 B-PV/V/C-F-31U3U3FG	99159332
				FKM	SS	DDE 60-10 B-SS/V/SS-F-31A1A1FG	99159333
60	10	AR	PVC	PTFE	SS	DDE 60-10 B-SS/T/SS-F-31A1A1FG	99159334
				EPDM	Ceramic	DDE 60-10 AR-PVC/E/C-F-31U3U3FG	99159335
			PVDF	FKM	Ceramic	DDE 60-10 AR-PVC/V/C-F-31U3U3FG	99159336
				EPDM	Ceramic	DDE 60-10 AR-PV/E/C-F-31U3U3FG	99159337
			SS	PTFE	Ceramic	DDE 60-10 AR-PV/T/C-F-31U3U3FG	99159338
				FKM	Ceramic	DDE 60-10 AR-PV/V/C-F-31U3U3FG	99159339
120	7	B	PVC	FKM	SS	DDE 60-10 AR-SS/V/SS-F-31A1A1FG	99159340
				PTFE	SS	DDE 60-10 AR-SS/T/SS-F-31A1A1FG	99159341
			PVDF	EPDM	Ceramic	DDE 60-10 AR-PV/E/C-F-31U3U3FG	99159342
				PTFE	Ceramic	DDE 60-10 AR-PV/T/C-F-31U3U3FG	99159343
			SS	FKM	Ceramic	DDE 60-10 AR-PV/V/C-F-31U3U3FG	99159344
				FKM	SS	DDE 60-10 AR-SS/V/SS-F-31A1A1FG	99159345
120	7	AR	PVC	PTFE	SS	DDE 60-10 AR-SS/T/SS-F-31A1A1FG	99159346
				EPDM	Ceramic	DDE 60-10 AR-PV/E/C-F-31U3U3FG	99159347
			PVDF	FKM	Ceramic	DDE 60-10 AR-PVC/V/C-F-31U3U3FG	99159348
				EPDM	Ceramic	DDE 60-10 AR-PV/E/C-F-31U3U3FG	99159349
			SS	PTFE	Ceramic	DDE 60-10 AR-PV/T/C-F-31U3U3FG	99159350
				FKM	Ceramic	DDE 60-10 AR-PV/V/C-F-31U3U3FG	99159351
200	4	B	PVC	FKM	SS	DDE 60-10 AR-SS/V/SS-F-31A1A1FG	99159352
				PTFE	SS	DDE 60-10 AR-SS/T/SS-F-31A1A1FG	99159353
			PVDF	EPDM	Ceramic	DDE 60-10 AR-PV/E/C-F-31U3U3FG	99159354
				PTFE	Ceramic	DDE 60-10 AR-PV/T/C-F-31U3U3FG	99159355
			SS	FKM	Ceramic	DDE 60-10 AR-PV/V/C-F-31U3U3FG	99159356
				FKM	SS	DDE 60-10 AR-SS/V/SS-F-31A1A1FG	99159357
200	4	AR	PVC	PTFE	SS	DDE 60-10 AR-SS/T/SS-F-31A1A1FG	99159358
				EPDM	Ceramic	DDE 60-10 AR-PV/E/C-F-31U3U3FG	99159359
			PVDF	FKM	Ceramic	DDE 60-10 AR-PVC/V/C-F-31U3U3FG	99159360
				EPDM	Ceramic	DDE 60-10 AR-PV/E/C-F-31U3U3FG	99159361
			SS	PTFE	Ceramic	DDE 60-10 AR-PV/T/C-F-31U3U3FG	99159362
				FKM	Ceramic	DDE 60-10 AR-PV/V/C-F-31U3U3FG	99159363
200	4	B	PVC	FKM	SS	DDE 60-10 AR-SS/V/SS-F-31A1A1FG	99159364
				PTFE	SS	DDE 60-10 AR-SS/T/SS-F-31A1A1FG	99159365
			PVDF	EPDM	Ceramic	DDE 60-10 AR-PV/E/C-F-31U3U3FG	99159366
				PTFE	Ceramic	DDE 60-10 AR-PV/T/C-F-31U3U3FG	99159367
			SS	FKM	Ceramic	DDE 60-10 AR-PV/V/C-F-31U3U3FG	99159368
				FKM	SS	DDE 60-10 AR-SS/V/SS-F-31A1A1FG	99159369

DDA, DDE, non-standard range

The codes used in the following tables are explained in the type key. See page 6.

DDA

Max. flow - press.	Control variant	DLD function	Materials			Control cube position	Supply voltage	Valve type	Connection inlet / outlet	Mains plug	Design	Special variant
			Head	Gaskets	Balls							
60-10 120-7 200-4	AR	NO	PVC PV	E V T	C	F	3	1 2	U3U3 A7A7	F B G I E J L	G	C3
			SS	E V T	SS	F	3	1 2	A1A1 A3A3			
		YES	PVC-L PV-L	E V T	C	F	3	1 2	U3U3 A7A7			
			SS-L	E V T	SS	F	3	1 2	A1A1 A3A3			
	FCM	NO	PVC PV	E V T	C	F	3	1 2	U3U3 A7A7			
			SS	E V T	SS	F	3	1 2	A1A1 A3A3			

DDE

Max. flow - press.	Control variant	DLD function	Materials			Control cube position	Supply voltage	Valve type	Connection inlet / outlet	Mains plug	Design	Special variant
			Head	Gaskets	Balls							
60-10 120-7 200-4	B AR	NO	PVC PV	E V T	C	F	3	1 2	U3U3 A7A7	F B G I E J L	G	C3
			SS	E V T	SS	F	3	1 2	A1A1 A3A3			

10. Accessories for medium-sized dosing pumps up to 460 l/h

Grundfos offer a comprehensive range of accessories covering every need when dosing with Grundfos pumps.

Accessories overview

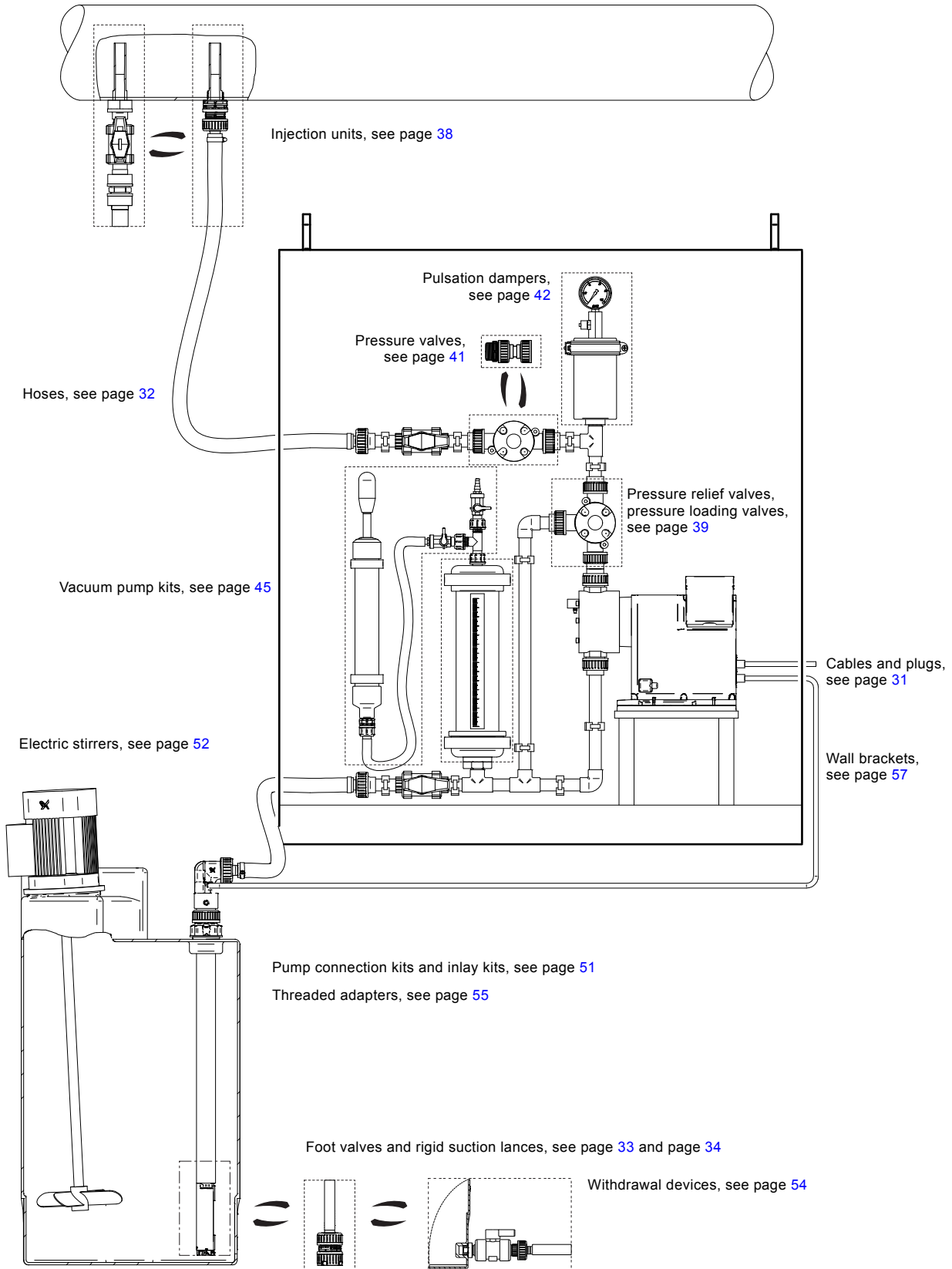

Fig. 25 Dosing pump with accessories

TM06 8374 0317

Cables and plugs

The listed cables and plugs are suitable for the connection of a pump to external control devices, such as process controllers, flow meters, start/stop contacts and level sensors.



TM01 8955 0900

Fig. 26 Cable and plug for DDA, DDE, DMX, DMH and DDI pumps

Technical data

- Cable material: PVC, 0.34 mm²
- Plug size: M 12

Socket for DDA and DDE	Socket for DMX, DMH and DDI	Application	Pins	Plug type	Cable length [m]	Product number	
	④	Input Analog pulse External stop	4	Straight	2	96609014	
					5	96609016	
					No cable	96698715	
	③	Output Relay 1 Relay 2	4	Straight	2	96693246	
					5	96609017	
					No cable	96609019	
	②	Output Analog	5	Straight	2	96696198	
					5	96698716	
					No cable	96632921	
	⑤	DDI	4	Straight	2	96632922	
					5	96609031	
					No cable	96699697	
-	⑤	DMX/ DMH AR	3	Straight with soldered cable	-	96698715	
					Input Low-level Empty tank	-	96630345
					Adapter, flat-round Low-level Empty tank	4	96635010
-	⑥	DDI	4	Profibus	-	96693735	
					Y-connector	-	96693737
					Terminating resistor	-	96693737
	-	Input/Output GENIbus	5	Straight	3	98589048	
-	-	Mains connection for DDI/DDA/DDE	3	Angled	-	96698717	

Hoses

Hoses in various materials, sizes and lengths for medium-sized dosing pumps.



Fig. 27 Hoses

TM01 8958 0900

Technical data

Max. flow rate [l/h]	Size internal/external diameter [mm]	Material	Max. pressure at 20 °C [bar]	Length [m]	Product number
200	13/20	PVC, textile reinforced	15	3	96727423
				10	96727420
				50	96692592
460	19/27	PVC, textile reinforced	12	3	96727426
				10	96696200
	19/24.6	PVC, reinforced with a plastic spiral	7	3	99168771

Foot valves FV

Foot valves are installed at the lower end of the inlet hose. They have no level indication.

Foot valves include:

- Strainer (mesh size approx. 0.8 mm)
- Non-return valve
- Hose and pipe connection set:
 - for hoses with internal diameter 19 or 20 mm
 - for pipes with external diameter 25 mm (PE includes PVC inlay, PVDF includes PVDF inlay)
- Pipe connection set: threaded, Rp 3/4", internal thread (stainless steel).

Remark: When using the foot valves with hose installation, a rigid pipe should be slipped over the hose to keep the suction line straight and upright in the tank.



TM06 8427 0517

Dimensions

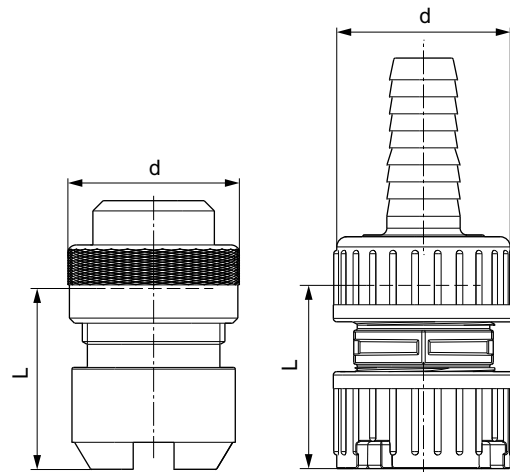

TM06 8075 4516

Fig. 28 Foot valves: stainless steel (left), PE/PVDF (right)

Material	L [mm]	d [mm]
PE/PVDF	57	53
SS	57	50

Technical data

Max. flow rate [l/h]	Materials			Product number
	Body	Gasket	Ball	
460	PE	FKM/EPDM	Ceramic	99168633
		PTFE	Ceramic	99168635
	PVDF	FKM/EPDM	Ceramic	99168636
		PTFE	Ceramic	99168649
	SS*	PTFE	SS*	99170593

* Body: SS 1.4571, 1.4435, 1.4305; Ball: SS 1.4401

Rigid suction lances RSL

Grundfos offer a comprehensive range of rigid suction lances for a variety of chemical containers.

Rigid suction lances are installed at the lower end of the inlet hose. They are available either without level indication or with low-level and empty-tank indication. Their immersion depth is adjustable.

Rigid suction lances include:

- Strainer (mesh size approx. 2.2 mm)
- Non-return valve
- Hose and pipe connection set:
 - for hoses with internal diameter 19 or 20 mm
 - for PVC pipes with external diameter 25 mm
- Adjustable tank connection with holes for a deaeration line.

Rigid suction lances with low-level and empty-tank indication include additionally:

- Reed switch unit with 2 floaters
- 5 metres of cable with PE jacket
- M 12 plug to connect DDA, DDE, DME or DDI dosing pumps.

The contact type of the low-level and empty-tank indication is factory-set to NO. The contact type can be set to NC by turning the floaters upside down.

Electrical data of the level indication:

- Max. voltage: 48 V
- Max. current: 0.5 A
- Max. load: 10 VA



Fig. 29 Rigid suction lance

TM06 8423 0517

Dimensions

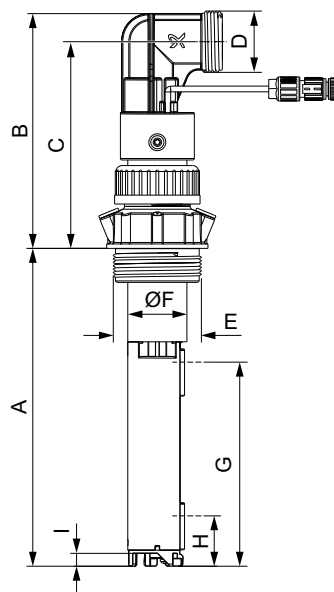

TM06 8130 0617

Fig. 30 Rigid suction lances

A	B	C	D	E	ØF	G*	H*	I
[mm]	[mm]	[mm]	[inch]	[inch]	[mm]	[mm]	[mm]	[mm]
500								
690	159	140	G 5/4	G 2	40	138	34	8.7
980								
1200								

* Switching level for water

Dimensions / Selection

For dosing tank type	Tank volume [l]	Recommended immersion depth (A) [mm]
Grundfos cylindrical tank	60	500
	100	690
	200	690
	300	980
	500	1200
Grundfos square tank	100	690
	120	980
L-ring drum*	220	980
	216	980
Steel drum*	33 (large cap)	500
	25, 30, 33	500
	60	690
IBC*	all sizes	1200

* Suitable adapters see [Accessories for rigid suction lances RSL](#), see page 35

Technical data

Max. flow rate [l/h]	Max. immersion depth (A) [mm]	Material in contact with liquid			Product No. without level indication	Product No. with level indication
		Body	Gasket	Ball		
460	500	PE	FKM/EPDM	Ceramic	99199363	99161410
			PTFE	Ceramic	99199364	99161411
	690	PE	FKM/EPDM	Ceramic	99199365	99161412
			PTFE	Ceramic	99199366	99161943
	980	PE	FKM/EPDM	Ceramic	99199367	99161944
			PTFE	Ceramic	99199368	99161945
	1200	PE	FKM/EPDM	Ceramic	99199369	99161946
			PTFE	Ceramic	99199370	99161947

Accessories for rigid suction lances RSL

Adapters for containers

These adapters allow the installation of standard rigid suction lances (G 2" thread) on different types of containers.



TM04 8506 0712

Fig. 31 Adapters for containers

Technical data

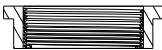
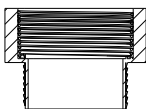
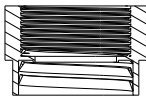
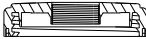
Adapter type	For container type	Remark	Product No.
	TM04 8470 0512 Containers without threaded opening, e.g. 100-litre square tank or 1000-litre cylindrical tank	PVC, grey	98071170
	TM04 8471 0512 Containers with 2" NPT threaded opening	PVC, grey	98156690
	Drums with S 70 x 6 coarse thread (MAUSER 2")	PE, blue	98071171
	Drums with S 56 x 4 coarse thread (TriSure®)	PE, orange	98071172
	TM04 8473 0512 Jerricans with medium-sized opening (approx. Ø45 mm), according to EN 12713	PE, yellow	98071174
	Jerricans with large opening (approx. Ø57 mm), according to EN 12713	PE, brown	98071175
	TM04 8472 0512 US containers with bung hole of 63 mm (ASTM International)	PE, white	98071176
	TM04 8472 0512 IBC (Intermediate Bulk Container) with opening of Ø150 mm, S 160 x 7	PE, black	98071177

Emission protection kits

Gas emitted by liquid in a container can cause bad odour and corrosion. Emission protection kits help avoid such problems. Rigid suction lances can be retrofitted with emission protection kits.

Two variants are available:

- Emission protection kit with snifting valve: no gas can escape from the container, but air can be drawn in.
- Emission protection kit for use with filter: gas can escape from the container and air can be drawn in. The kit can be connected to a filter by means of a 4/6 mm hose.

Emission protection kits include:

- Gasket for the tank adapter
- Snifting valve or hose nipple 4/6 mm (hose is not included)
- Gasket for the cable outlet.

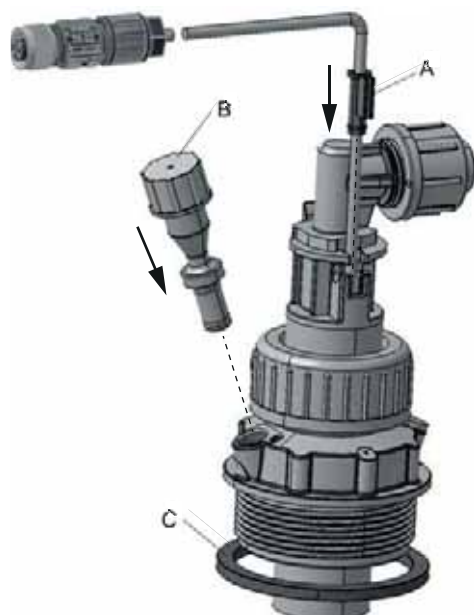

TMD06 8372 0317

Fig. 32 Emission protection kit

Position	Description
A	Gasket for the cable outlet
B	Air valve
C	Gasket for the tank adapter

Order data

Variant	Product number
Emission protection kit with snifting valve	98071178
Emission protection kit for use with filter	98071179

M 12-plug-to-flat-plug adapter

The adapter allows to connect rigid suction lances or foot valves with level indication to pumps with a level input designed for flat plugs (e.g. DMX and DMH with AR control unit).

Order data

Description	Product number
M12-plug-to-flat-plug adapter	96635010

Level-control units

Grundfos level-control units are suitable for dosing pumps with input for level control.

The contact type of the reed switch unit is factory-set to NO. The contact type can be set to NC by turning the floater(s).

Electrical data

- Max. voltage: 48 V
- Max. current: 0.5 A
- Max. load: 10 VA

Level-control unit for electric stirrer protection

Level-control units for electric stirrer protection are used for rigid suction lances for pumps up to 60 or 460 l/h. They are clipped to the rigid suction lances at the required switch-off height above the stirrer propeller.

Level-control units can also be used for overflow protection or as an additional tank level indication.

A level-control unit for electric stirrer protection includes:

- Reed switch unit with 1 floater
- 5 m cable with PE jacket and open wire ends
- Clip for diameter 40 mm or 32 mm
- Cable gland for mounting at the tank top

Dimensions

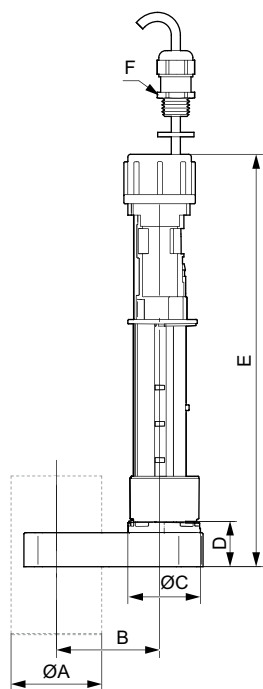

TM06 8304 5116

Fig. 33 Level-control unit for electric stirrer protection

ØA [mm]	B [mm]	ØC [mm]	D [mm]	E [mm]	F
40	47.5	32	20	182	M 12 x 1.5
32	43	32	28	190	M 12 x 1.5

Technical data

Description	Material	ØA [mm]	Product number
Level-control unit for electric stirrer protection	PE	32	98306210
		40	99174140

Flexible level-control unit

The flexible level-control unit is suitable for dosing pumps with level-control input and provides 2 level switches.

A flexible level-control unit includes:

- Reed switch unit with 2 floaters
- 5 m of cable with PE jacket and M 12 plug
- Weight that keeps the level-control unit in an upright position at the tank bottom
- PE cap, Ø58 mm, for assembly in Grundfos cylindrical tanks, or for use with tank adapters

Dimensions

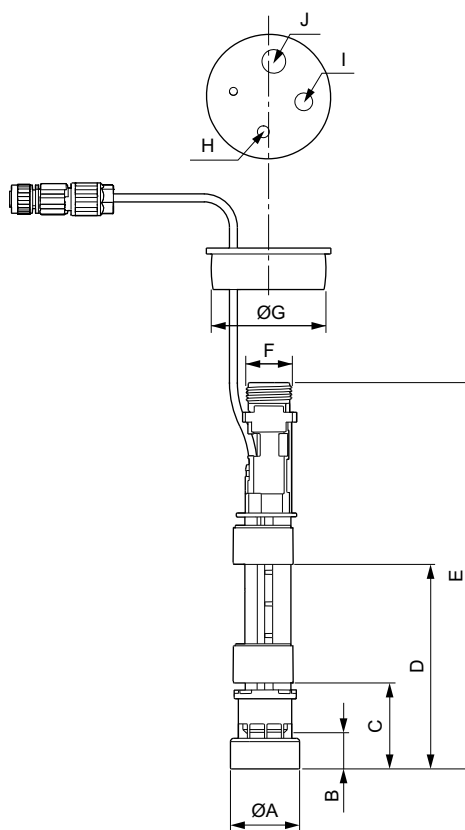

TM06 8102 4616

Fig. 34 Flexible level-control unit

ØA [mm]	B [mm]	C [mm]	D [mm]	E [mm]	F [inch]	ØG [mm]	H [mm]	I [mm]	J [mm]
35	19	43.5	103.5	196	G 5/8	58	6	9	12

Technical data

Description	Material	Product number
Flexible level-control unit	PE	98375695

Injection units

Injection units connect the dosing line with the process line. They ensure a minimum counterpressure of 0.7 bar, and avoid backflow of the dosing medium.

In general they include:

- Injection pipe with immersion depth of 120 mm. PP, PVC and PVDF versions can be shortened.
- Spring-loaded non-return valve with 2.4610 (Alloy C-4) spring.
- Hose and pipe connection set (PVC, PP, PVDF):
 - for hose with internal diameter 19 or 20 mm
 - for pipe with external diameter 25 mm
- Pipe connection set (stainless steel): threaded, Rp 3/4", internal thread.

Standard injection units



TM06 8428 0517

Dimensions

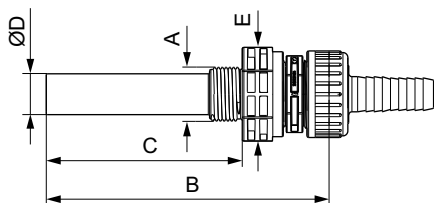

TM06 8076 4516

Fig. 35 Injection unit

A [inch]	B [mm]	C [mm]	ØD [mm]	Wrench size E [mm]
G 1	173	120	26.9	PP, PVC, PVDF SS 46

Technical data

Max. flow rate [l/h]	Materials			Product number
	Body	Gasket	Ball	
460	PVC	FKM	Ceramic	99168657
		EPDM	Ceramic	99168658
		PTFE	Ceramic	99169217
	PP	FKM	Ceramic	99169220
		EPDM	Ceramic	99169223
	PVDF	FKM	Ceramic	99169227
		EPDM	Ceramic	99169228
		PTFE	Ceramic	99169229
	SS*	PTFE	SS**	99169230

* SS 1.4571 and SS 1.4408
** SS 1.4401

Injection units with ball valve

Injection units with ball valve are used for applications where the injection point must be closable. The ball valve is placed between the injection pipe and the spring-loaded non-return valve. Thus, the dosing line can be completely disconnected from the process. The non-return valve can be disassembled and cleaned without stopping the process and emptying the process line.



TM06 8429 0517

Dimensions

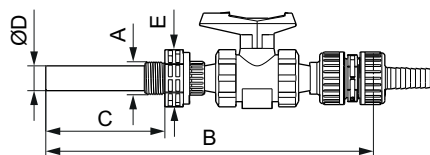

TM06 8370 0317

Fig. 36 Injection unit with ball valve, PVC version

A [inch]	B [mm]	C [mm]	ØD [mm]	Wrench size E [mm]
G1	330	120	25	50

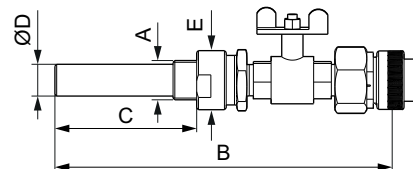

TM06 8371 0317

Fig. 37 Injection unit with ball valve, stainless steel version

A [inch]	B [mm]	C [mm]	ØD [mm]	Wrench size E [mm]
G1	285.5	120	26.9	46

Technical data

Max. flow rate [l/h]	Materials			Product number
	Body	Gasket	Ball	
460	PVC	FKM	Ceramic	99206582
		EPDM	Ceramic	99206585
	SS*	PTFE	SS**	99206586

* SS 1.4571 and SS 1.4408
** SS 1.4401

Pressure relief valves PRV

Pressure relief valves protect the pump and the outlet-side installations against excessive pressure. All pressurised dosing installations should include a pressure relief valve.

Pressure relief valves are installed in the outlet line near the pump using the 2 in-line connections. The side connection leads the relief liquid back into the tank.

- Relief pressure, adjustable from 3 to 10 bar, is factory-set to 10 bar
- Maximum operating pressure 10 bar
- Hose and pipe connection set (PVC, PP, PVDF):
 - for hoses with internal diameter 19 or 20 mm
 - for pipes with external diameter 25 mm
- Pipe connection set (stainless steel): threaded, Rp 3/4", internal thread.



Fig. 38 Pressure relief valve

TM06 8421 0517

Dimensions

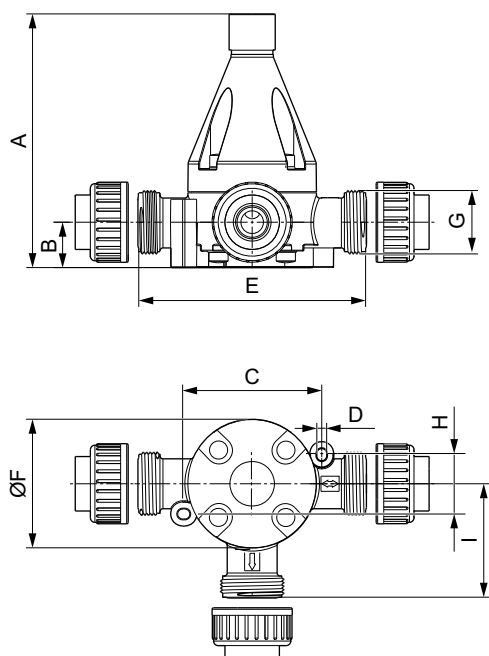

TM06 8077 4516

Fig. 39 Pressure relief valve (PP, PVC, PVDF version)

A	B	C	D	E	ØF	G	H	I
[mm]	[mm]	[mm]	[mm]	[mm]	[mm]	[inch]	[mm]	[mm]
168	30	92	6.5	150	85	G 5/4	40	75

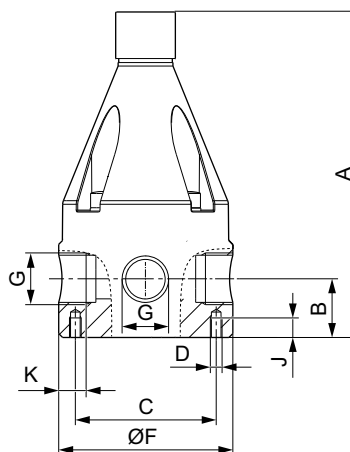

TM06 8247 4916

Fig. 40 Pressure relief valve, stainless steel version

A	B	C	D	ØF	G	J	K
[mm]	[mm]	[mm]		[mm]	[inch]	[mm]	[mm]
167	30	63	M 6	89	Rp 3/4	10	17.5

Technical data

Max. flow rate [l/h]	Materials		Product number
	Body	Gasket	
460	PVC	FKM/EPDM	99131032
		PTFE	99141139
	PP	FKM/EPDM	99141197
		FKM/EPDM	99141212
	PVDF	PTFE	99141224
		SS	-

* SS 1.4571

Pressure loading valves PLV

Pressure loading valves maintain a constant counterpressure for the dosing pump.

They are used in the following applications:

- Too low counterpressure or no counterpressure at all
- Fluctuating system pressure with outlet-side-side pulsation damper.
- To prevent syphoning, when the inlet pressure is higher than the counterpressure.

Pressure loading valves are installed in the outlet line after the pressure relief valve, and after the pulsation damper, if fitted.

- Opening pressure, adjustable from 3 to 10 bar, is factory-set to 3 bar.
- Maximum operating pressure: 10 bar.
- Hose and pipe connection set (PVC, PP, PVDF):
 - for hoses with internal diameter 19 or 20 mm
 - for pipes with external diameter 25 mm
- Pipe connection set (stainless steel): threaded, Rp 3/4", internal thread.

Pressure loading valves must not be used as shut-off valves.



Fig. 41 Pressure loading valve

TM06 8422 0517

Dimensions

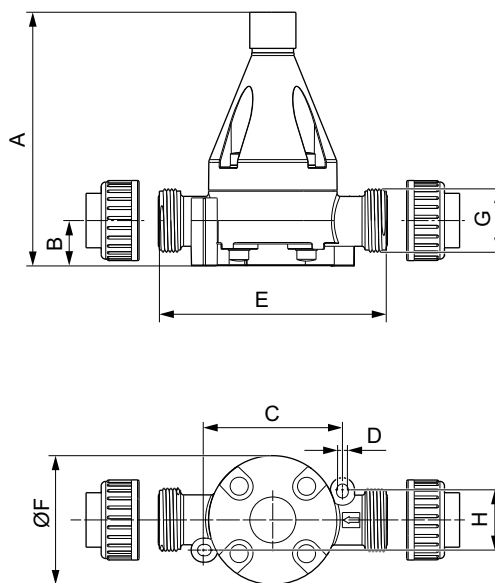

TM06 8090 4516

Fig. 42 Pressure loading valve (PP, PVC, PVDF version)

A [mm]	B [mm]	C [mm]	D [mm]	E [mm]	ØF [mm]	G [inch]	H [mm]
168	30	92	6.5	150	85	G 5/4	40

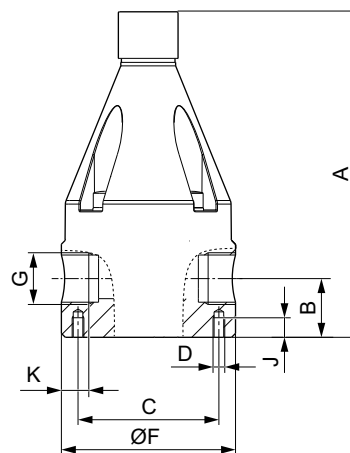

TM06 8246 4916

Fig. 43 Pressure loading valve, stainless steel version

A [mm]	B [mm]	C [mm]	D	ØF [mm]	G [inch]	J [mm]	K [mm]
167	30	63	M 6	89	Rp 3/4	10	17.5

Technical data

Max. flow rate [l/h]	Materials		Product number
	Body	Gasket	
460	PVC	FKM/EPDM	99132186
		PTFE	99140593
	PP	FKM/EPDM	99140610
		FKM/EPDM	99140646
	PVDF	FKM/EPDM	99140646
		PTFE	99140651
SS*	-	99141228	

* SS 1.4571

Pressure valves PV

Pressure valves provide a constant counterpressure of 3 bar. They are particularly required for DDA-FCM pumps at very small flow rates.

Pressure valves are installed either directly on the pump discharge side, or on the pressure relief valve.

- Loading pressure: 3 bar, not adjustable
- Maximum system pressure: 10 bar
- Spring material: 2.4610 (Alloy C-4)
- No connections included.

Dimensions

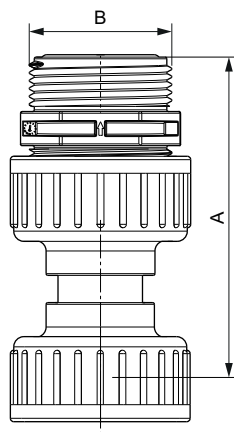

TM06 8404 0417

Fig. 44 Pressure valve

Material	A [mm]	B [inch]
PVC PVDF	94	G 5/4
SS	100	G 5/4

Technical data

Max. flow rate [l/h]	Material			Product number
	Body	Ball	Gaskets	
200	PVC	Ceramic	EPDM	99229021
			FKM	99229033
	PVDF	Ceramic	EPDM	99229018
			FKM	99229020

Pulsation dampers and calibration columns

Pulsation dampers are used to even out the pulsating flow and pressure produced by positive displacement pumps like diaphragm dosing pumps. They can be installed before and after the pump.

Discharge side pulsation dampers DB and DBG

Pulsation dampers DB and DBG are especially designed for installations with long outlet lines with a small diameter, or with rigid pipes. The pulsation dampers optimise the dosing accuracy and protect the pump and the outlet line against pressure surges.

If the counterpressure in the system is low or fluctuating, the installation of a pressure loading valve PLV after the pulsation damper may be required to optimise its function.

Pulsation dampers DB and DBG have an air or nitrogen cushion inside, which is separated from the dosing medium by a separating diaphragm. This keeps the charging pressure stable for a long time and avoids that air or nitrogen is dissolved in the dosing medium. For proper operation, the pressure in the air or nitrogen cushion must be set to approximately 80 % of the system pressure.

In PVC, PP, and stainless steel pulsation dampers, an FKM or EPDM bladder is used as separating diaphragm, in PVDF pulsation dampers a PTFE bellows is used as separating diaphragm.

Grundfos SMART Digital dosing pumps do not require a DB or DBG pulsation damper, if the flow rate is limited to 75 % of the maximum dosing capacity of the pump. In rigid pipe installations, the flow rate without pulsation damper should not exceed 50 % of the maximum dosing capacity of the pump.

Pulsation dampers DBG include a pressure gauge for easy setting of the correct pressure. Pulsation dampers DB have no pressure gauge.

Suction-side pulsation dampers CSD with calibration scale

Pulsation dampers CSD help to ensure the accuracy of dosing pumps, which is highly dependent on proper suction conditions. In installations with long inlet lines or inlet lines with a small diameter, the use of a CSD pulsation damper is recommended.

Pulsation dampers CSD have a transparent PVC cylinder with a fine volume scale. When combined with a shut-off valve in the inlet line, they can also be used for calibration or flow measurement. In installations without flooded suction, the optional manual vacuum pump kit simplifies the startup of the dosing pump.

Pulsation dampers CSD can be used for multiple pumps that are supplied by the same inlet line.

Calibration columns

Calibration columns have a graduated glass cylinder with a fine scale. A shut-off valve on the lower end can disconnect them from the inlet-side installation during normal operation.

One calibration column can be used for multiple pumps that are supplied by the same inlet line.

Calibration columns must not be used as pulsation dampers.



Fig. 45 Pulsation dampers CSD, DBG and DB

TM06 8449 0617

Sizing guide for pulsation dampers DB, DBG, CSD and calibration columns

Look up your pump type in the table. Find the required pulsation damper or calibration column volume in the respective table column.

Pump types	Pump stroke volume [ml]	Required damper volume		Required calibration column volume [l]
		DB/DBG [l]	CSD [l]	
DDC-DDE 6-10	0.81	0.15	0.25	0.25
DDA 7.5-16*	0.74			
DDC 9-7	0.84			
DDA 12-10	1.45			
DDC-DDE 15-4	1.58			
DDA 17-7	1.55			
DDA 30-4*	3.1			
DDI 60-10	6.67			
DMX 4-10	2.2			
DMX 8-10				
DMX 16-10				
DMX 7-10	3.8			
DMX 14-10				
DMX 27-10				
DMX 9-10	4.9			
DMX 18-10				
DMX 35-10				
DMX 12-10	6.9			
DMX 26-10				
DMX 50-10				
DMH 5-10	3.5			
DMH 13-10				
DMH 24-10				
DMH 11-10	6.4			
DMH 24-10				
DMH 46-10				
DDA/DDE 60-10	5.56	0.3 - 0.35	1.5	2.0
DDA/DDE 120-7	11.58			
DDA/DDE 200-4	19.3			
DME 60-10**	6.25			
DME 150-4	15.6			
DDI 150-4	13.9			
DMX 17-4	10.4			
DMX 39-4				
DMX 75-4				
DMX 25-3	16			
DMX 60-3				
DMX 115-3				
DMX 24-8	13.8			
DMX 52-8				
DMX 100-8				
DMX 142-8	18.5			
DMX 67-10				
DMX 132-10				
DMX 190-10	11.3			
DMH 21-10				
DMH 43-10				
DMH 67-10				
DMH 83-10				
DMH 100-10				

Pump types	Pump stroke volume [ml]	Required damper volume		Required calibration column volume [l]
		DB/DBG [l]	CSD [l]	
DMX 37-5	22	0.65 - 0.7	3.0	4.0
DMX 82-5				
DMX 160-5				
DMX 230-5	27.8			
DMX 95-8				
DMX 199-8				
DMX 280-8	36			
DMX 60-3				
DMX 130-3				
DMX 255-3	44.6			
DMX 380-3				
DMX 152-6				
DMX 321-6	31.6			
DMX 460-6				
DMH 50-10				
DMH 102-10				
DMH 143-10				
DMH 175-10				
DMH 213-10				
DMH 291-10				

* For very low remaining pulsation, a larger damper than mentioned in the sizing guide should be used.

** A smaller damper than mentioned in the sizing guide is sufficient, if a high remaining pulsation is acceptable.

Suction-side pulsation dampers CSD with calibration scale

Pulsation dampers CSD are installed on the inlet side of the dosing pump. A pulsation damper CSD can be used for more than one pump at a time.

- Prepared for pipe gluing connection with spigot (D) or socket (d).
- Calibration is possible by installing a T-piece and a shut-off valve.
- In installations without flooded suction, the optional manual vacuum pump kit simplifies the startup of the dosing pump. See [Manual vacuum pump kit](#) on page 45.

Pulsation dampers CSD include:

- Sight glass with calibration scale
- Aeration valve



TM06 8450 0617

Fig. 46 Pulsation damper CSD with calibration function

Dimensions

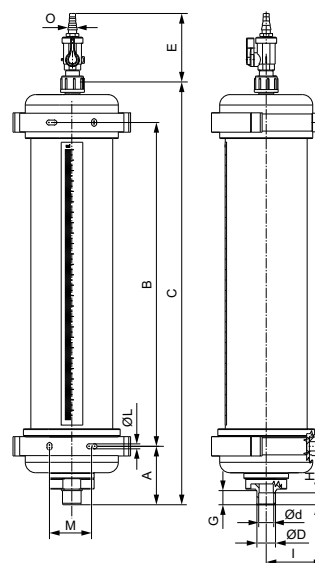

TM06 8373 0317

Fig. 47 Pulsation damper CSD with calibration function

Damper volume [l]	A [mm]	B [mm]	C [mm]	ØD/Ød [mm]	E [mm]	G [mm]	H [mm]	I [mm]	ØL [mm]	ØM [mm]	O [mm]
0.25	50	270	360	16/12	92	14	12	40		-	
0.5	50	340	431	16/12	92	14	12	47	6.5	-	8-13
1.5	75	343	465	25/20	92	19	16	70		40	
3.0	79	435	568	25/20	92	19	16	78		60	

Technical data

Damper volume [l]	Max. pump stroke volume [ml]	Max. number of pumps with max. stroke volume	Scale division [ml]	Pipe connection ØD/Ød [mm]	Materials			Product number
					Body	Sight glass	Gasket	
0.25	2	3	2	16/12	PVC	PVC	FKM/EPDM	99186948
							PTFE	99217401
0.5	7	3	5	16/12	PVC	PVC	FKM/EPDM	99187777
							PTFE	99217402
1.5	19	3	20	25/20	PVC	PVC	FKM/EPDM	99188854
							PTFE	99217403
3.0	45	2	25	25/20	PVC	PVC	FKM/EPDM	99190807
							PTFE	99217406

Manual vacuum pump kit

In installations without flooded suction, the pulsation damper CSD can be filled with the manual vacuum pump kit. This makes the startup of the dosing pump easier and prepares the pulsation damper CSD for the calibration of the pump.

A manual vacuum pump kit includes:

- Ball valve, connection G 5/8"
- T-piece, connection G 5/8"
- Hose
- Manual vacuum pump
- Holder for wall mounting

Materials:

- Vacuum pump: PVC
- Ball valve and T-piece: PVC
- Gasket: FKM



Fig. 48 Manual vacuum pump kit

TM06 8426 0516

Dimensions

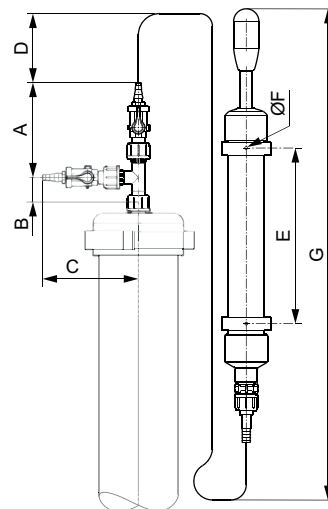

TM06 8376 0317

Fig. 49 Manual vacuum pump kit

A [mm]	B [mm]	C [mm]	D [mm]	E [mm]	ØF [mm]	G _{min} [mm]	G _{max} [mm]
131	34	132.5	50	242	6.2	675	875

Order data

Description	Product number
Manual vacuum pump kit	99218131

Calibration columns

Calibration columns are intended for flow measurement or calibration of dosing pumps. They must be isolated from the pipework during normal operation.

The volume in the calibration column can supply the largest suitable pump for approximately 30 seconds.

Calibration columns include:

- Glass cylinder with acrylic outer shield
- Aeration valve on top
- Shut-off valve on the bottom

In installations without flooded suction, the optional manual vacuum pump kit simplifies the startup of the dosing pump. See [Manual vacuum pump kit](#) on page 45.

Calibration columns must not be used as pulsation dampers.

Dimensions

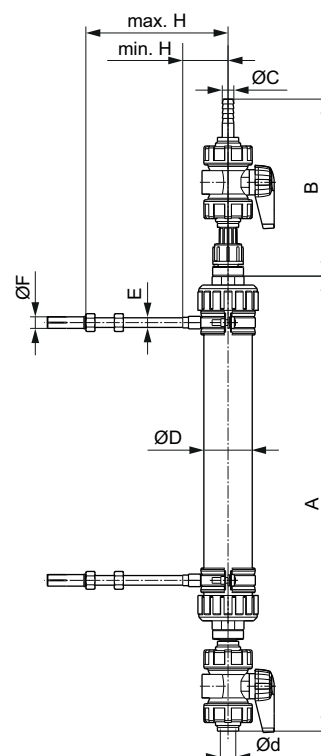

TM06 8405 0517

Fig. 50 Calibration columns

Volume [l]	Body	A [mm]	B [mm]	ØC [mm]	ØD [mm]	E [mm]	ØF [mm]	H _{min-max} [mm]
0.25	PVDF	478	184	12	50.8	M 10	12	50-154
	SS	460	140					
0.5	PVDF	517	184	12	69.85	M 10	12	61-165
	SS	498	140					
2.0	PVDF	675	188	12	101.6	M 10	12	78-182
	SS	657	148					
4.0	PVDF	795	188	12	132	M 10	12	92-196
	SS	777	148					

Technical data

Volume [l]	Max. pump stroke volume [ml]	Scale division [ml]	Pipe connection Ød		Material		Product number
			[mm]	[inch]	Body	Gasket	
0.25	2	2	16	-	PVDF	FKM	99224280
			-	G 1/2	SS	FKM	99224303
			-	G 1/2	SS	EPDM	99224304
0.5	7	5	16	-	PVDF	FKM	99224305
			-	G 1/2	SS	FKM	99224307
			-	G 1/2	SS	EPDM	99224308
2.0	19	20	25	-	PVDF	FKM	99224309
			-	G 1	SS	FKM	99224310
			-	G 1	SS	EPDM	99224311
4.0	45	25	25	-	PVDF	FKM	99224312
			-	G 1	SS	FKM	99224313
			-	G 1	SS	EPDM	99224314

Vacuum pump kit for calibration columns

In installations without flooded suction, the calibration column can be filled with the vacuum pump kit. This makes the startup of the dosing pump easier and prepares the calibration column for pump calibration.

A vacuum pump kit for calibration columns includes:

- Ball valve, connection G 5/8"
- T-piece, connection G 5/8"
- Hose
- Manual vacuum pump
- Holder for wall mounting

Materials:

- Vacuum pump: PVC
- Ball valve and T-piece: PVDF
- Gasket: FKM

Dimensions

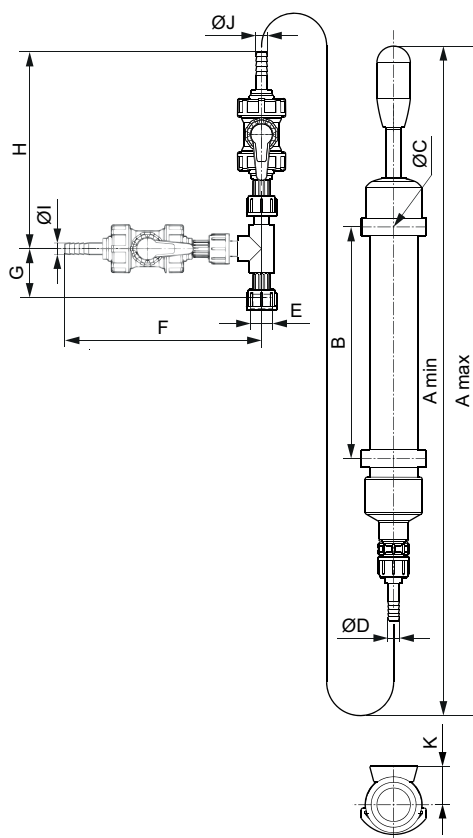

TM06 8412 0517

Fig. 51 Vacuum pump kit

Dimension	Unit	Value
A _{min-max}	[mm]	700-875
B	[mm]	242
ØC	[mm]	6.1
ØD	[mm]	12
E	[inch]	G 5/8
F	[mm]	206
G	[mm]	51
H	[mm]	206
ØI	[mm]	12
ØJ	[mm]	12
K	[mm]	40

Order data

Description	Product number
Vacuum pump kit for calibration columns	99226934

Discharge-side pulsation dampers DB and DBG

Pulsation dampers DB and DBG have a separating diaphragm and are intended for the outlet side of the dosing pump. We recommend using one pump per pulsation damper.

- Pre-load pressure: 2.7 bar.

Pulsation dampers DB and DBG include:

- Material for wall mounting
- PVC versions are prepared for pipe gluing connection with spigot (D) or socket (d).
- PVDF and PP versions are prepared for pipe welding connection with spigot (D) or socket (d).
- Pulsation dampers DBG include a pressure gauge.



Fig. 52 Pulsation damper DBG with separating diaphragm and pressure gauge

TM06 8424 0517

Dimensions

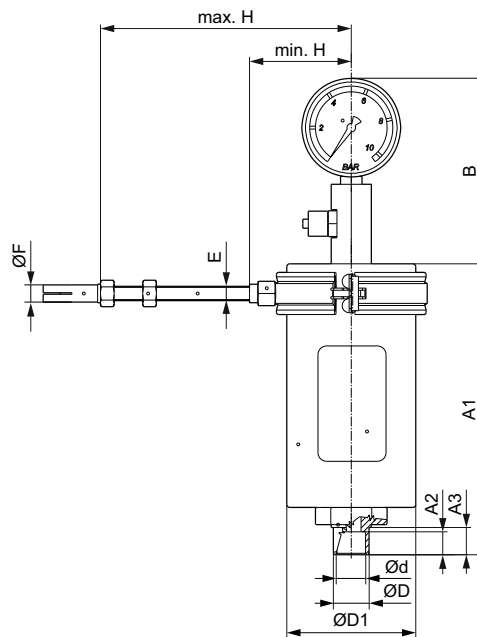

Fig. 53 Pulsation damper DBG, PVC version

TM06 8284 5016

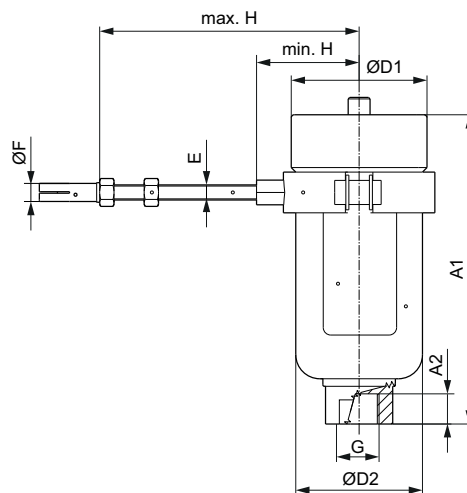

Fig. 54 Pulsation damper DB, stainless steel version

TM06 8452 0617

Nominal damper volume [l]	Actual damper volume [l]	Material	Pipe connection [mm]		A1 [mm]	A2 [mm]	A3 [mm]	D1 [mm]	D2 [mm]	H _{min} -H _{max} [mm]	G internal thread [inch]	F [mm]	B [mm]	E
			Body	Ø D										
0.15	0.15	PVDF	16	12	205	12	14	70	53	53-127	-			
	0.18	PVC	16	12	161	12	14	80	-	67-171	-			
		PP	-	-	118	14	-	70	-	64-168	G 1/2			
0.35	0.3	PVDF	25	20	267	20	25	84	63	58-175	-			
	0.36	PVC	25	20	203	20	25	90	-	71-175	-	12	129	M 10
		PP	-	-	161	16-	-	85	-	67-171	G 3/4			
0.65	0.65	PVC	25	20	263	20	25	100	-	78-152	-			
		PP	-	-	205	20	-	90	84	67-171	G 3/4			
	0.7	PVDF	25	20	138	20	25	125	84	67-171	-			

* SS 1.4404

Technical data

Nominal damper-volume [l]	Max. pump stroke volume [ml]	Pipe connection		Max. operating pressure [bar]	Material		Product number	
		ØD/Ød [mm]	G internal thread [inch]		Body	Gasket	Type DB (without pressure gauge)	Type DBG (with pressure gauge)
0.15	7	16/12	-	10	PVC	FKM	99202642	99202679
						EPDM	99202653	99202680
			G 1/2	180	PP	FKM	99202654	99202681
						EPDM	99202657	99202682
		16/12		20	SS*	FKM	99202660	99202684
						EPDM	99202661	99202685
0.35	19	25/20	-	10	PVDF	PTFE	99202658	99202683
						FKM	99202662	99202687
			G 1/2	130	PP	EPDM	99202663	99202688
						FKM	99202664	99202689
				130	SS*	EPDM	99202665	99202690
						FKM	99202667	99202692
0.3	19	25/20		20	PVDF	PTFE	99202666	99202691
0.65	45	25/20	-	10	PVC	FKM	99202670	99202694
						EPDM	99202671	99202695
			G 3/4	50	PP	FKM	99202672	99202696
						EPDM	99202673	99202697
				50	SS*	FKM	99202675	99202699
						EPDM	99202676	99202700
0.7	45	25/20		16	PVDF	PTFE	99202674	99202698

* SS 1.4404

Filling devices for pulsation dampers DB and DBG

Filling devices for plastic or stainless-steel pulsation dampers

Filling devices make the adjustment of the pre-charging pressure of pulsation dampers easy. The filling device is connected to a local compressed-air or nitrogen source and the filling valve of a pulsation damper. It can be removed when the pressure is adjusted.

Filling devices are available with different pressure gauges.

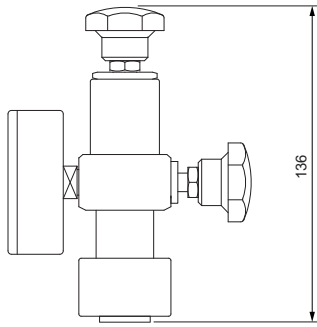

TM06 8068 4516

Fig. 55 Filling device for plastic or stainless-steel pulsation dampers

Description	Connection [inch]	Max. operating pressure [bar]	Product number
Filling device with pressure gauge	G 1/4	25	96727342
		60	96727343
		160	96727344
		250	96727345

Tyre-valve adaptor

A tyre-valve adaptor allows the use of common air pumps with tyre valves for filling the pulsation damper with air.

Dimensions

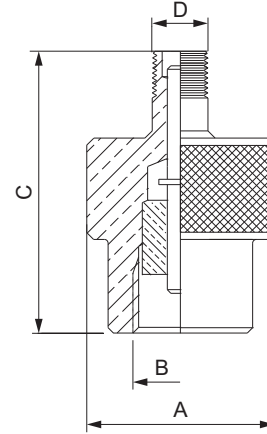

TM06 8142 4716

Fig. 56 Tyre-valve adaptor

A [mm]	B [inch]	C [mm]	D [mm]
25	G 1/4	38	Vg 8

Order data

Description	Product number
Tyre-valve adaptor, up to 8 bar, for use in conjunction with compressed-air filling device or pressure gauge	96727332

Pump connection kits and inlay kits

Retrofit pump connection kits and inlay kits for the integration of Grundfos standard dosing pumps into installations with various sizes of hoses or pipes.

A pump connection kit includes:

- 1 set of inlays
- 1 union nut

The inlay kits are used to connect pumps and accessories to pipes or hoses that differ from Grundfos standard sizes.

An inlay kit includes:

- 2 sets of inlays



Fig. 57 Pump connection kit

TM06 8425 0517



Fig. 58 Inlay kit

TM06 8430 0517

Technical data

Application	Connection type	For hose/pipe size		Connector type key code	Material	Product number	
		Internal	External			Connection kit	Inlay kit
Hose connection	Nipple and clamp	19/20 mm	-		PP	99082037	-
Pipe connection	Gluing or welding inlay	-	25 mm	U3	PVC	99082038	-
					PVDF	99082039	-
Hose connection	Cone and ring	13 mm	20 mm	A6	PVC	91835696	99170747
Hose connection	Nipple and clamp	19/20 mm or 3/4"	-	Q	PP	99169576	99169735
					PVC	99169603	99169740
Pipe connection	Welding inlay	-	25 mm	B4	PVDF	99169728	99169738
					PP	91835697	99171119
Pipe connection	Gluing inlay	-	25 mm	B0	PVDF	91835698	99171146
					PVC	96701989	99171177
Pipe connection	Internal thread	3/4" NPT	-	A7	PVC	99170858	99171222
					PVDF	99170858	99171222
Pipe connection	External thread	-	Rp 3/4"	A1	PVC	99082040	99171707
					PP	99082041	99171776
Pipe connection	Cutting-ring type	19 mm	22 mm	C3	PVDF	99082042	99171793
					PP	99082043	99182104
Pipe connection	External thread	-	Rp 3/4"	A1	PVDF	99082044	99182109
					SS*	99082045	99182114
Pipe connection	External thread	-	3/4" NPT	A3	Alloy C-4**	99082046	99182136
					PP	99082047	99174974
Pipe connection	Cutting-ring type	19 mm	22 mm	C3	PVDF	99082048	99175004
					SS*	99082049	99175015
Pipe connection	Cutting-ring type	19 mm	22 mm	C3	Alloy C-4**	99082050	99175031
					SS*	96727555	-

* Union nut: SS 1.4401, inlay: SS 1.4571

** 2.4610 (Alloy C-4)

Electric stirrers

Electric stirrers are intended for the mixing and dissolving of non-abrasive, non-inflammable and non-explosive liquids. They ensure that the liquid in the dosing tank is mixed constantly. With a frequency of 50 Hz they run at approximately 1500 rpm. Electric stirrers are suitable for liquids with low to medium viscosity.

Dimensions

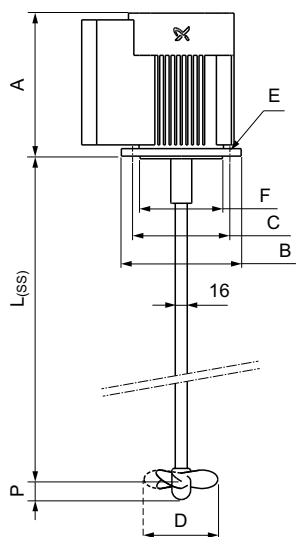

TM04 8638 4112

Fig. 59 Electric stirrer, stainless-steel version

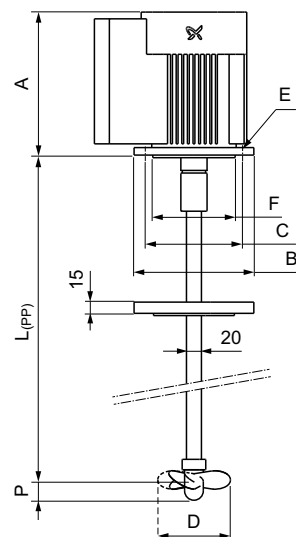

TM04 8639 4112

Fig. 60 Electric stirrer, PP version with sealing flange

Tank size [l]	L _(SS) [mm]	L _(PP) [mm]	A [mm]	B [mm]	C [mm]	D [mm]	E [mm]	F [mm]	P [mm]
60	450	452	210	140	115	88	9	95	25
100	691	693	210	140	115	88	9	95	25
200	698	700	191	160	130	100	9	110	25
300	950	952	191	160	130	100	9	110	25
500	1100	1102	191	160	130	125	9	110	28
1000	1150	1152	231	200	165	125	11	130	28

Technical data

Tank size [l]	Nominal shaft length [mm]	Material, Type	Product number	
			Single-phase motor	Three-phase motor
60	450	SS	98164569	98165309
		PP	98164573	98165310
		PP, with sealing flange	98164575	98165318
100	690	SS	98164606	98165355
		PP	98164607	98165357
		PP, with sealing flange	98164609	98165382
200	690	SS	98164987	98165385
		PP	98164990	98165386
		PP, with sealing flange	98165152	98165391
300	950	SS	98165172	98165393
		PP	98165175	98165432
		PP, with sealing flange	98165177	98165433
500	1100	SS	98165253	98165435
		PP	98165258	98165436
		PP, with sealing flange	98165259	98165437
1000	1150	SS	98165287	98165439
		PP	98165290	98165440
		PP, with sealing flange	98165304	98165451

Motor data of electric stirrers

Tank size [l]	Power rating [kW]	Motor phases	Voltage [V]	Frequency [Hz]	Enclosure class	Insulation class
60	0.09	1	220-240	50/60	IP65	F
100		3	220-240 / 380-420 (440-480)	50/60 (60)		
200	0.25	1	220-230	50	IP55	F
300		3	220-240 / 380-415	50/60		
500		3	220-240 / 380-415	50/60		
1000	0.55	1	220-230	50	IP55	F
		3	220-240 / 380-415	50/60		

Withdrawal devices

A withdrawal device is designed for installation in the drain opening of a Grundfos tank. Hose or pipe connection kits are included.

- Hose connection kit up to 60 l/h: 4/6 mm, 6/9 mm, 6/12 mm and 9/12 mm
- Hose and pipe connection kit up to 460 l/h:
 - for hoses with internal diameter 19 or 20 mm
 - for pipes with external diameter 25 mm

Dimensions

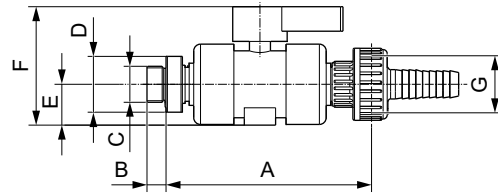

TM06 84 14 0517

Fig. 61 Withdrawal device, G 5/4"

Max. flow [l/h]	A [mm]	B [mm]	C [inch]	D [mm]	E [mm]	F [mm]	G [inch]
60	143				27	75	G 5/8
460	151	14	G 3/4	41	30	87	G 5/4

Technical data

Max. flow [l/h]	Description	Material		Product number
		Body	Gasket	
60	Withdrawal device with ball valve with through-bolt for connection to the dosing tank	PVC	FKM	99226879
			EPDM	99226880
460	Withdrawal device with ball valve with through-bolt for connection to the dosing tank	PVC	FKM	99226881
			EPDM	99226893

Adapters

Threaded adapters

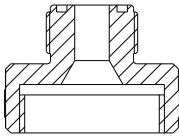
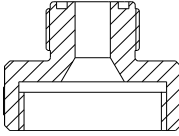
Application example	Type	Threaded connection size		Materials		Product number
		Internal thread	External thread	Body	Gaskets	
DN 20 → DN 10	 TM06 8416 0517	G 5/4"	G 3/4"	PP	FKM/EPDM	99227512
				PVC	FKM/EPDM	99227511
					PTFE	99228197
				PVDF	FKM/EPDM	99227829
DN 32 → DN 20	 TM06 8417 0517	G 2"	G 5/4"	PP	FKM/EPDM	99227945
				PVC	FKM/EPDM	99227943
					PTFE	99227960
				PVDF	FKM/EPDM	99227953
				PVDF	PTFE	99227948

Union nut adapters

A union nut adapter allows the direct assembly of a pressure loading valve PLV or a pressure relief valve PRV on the pump outlet valve.

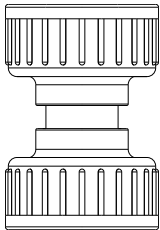
Type	Threaded connection size		Body material	Product number
	Internal thread	Internal thread		
 TM06 8418 0517	G 5/4"	G 5/4"	PP	99228667
			PVC	99228665
			PVDF	99228669

Elbow adapter

An elbow adapter can be installed, if the space on the inlet side of the pump is confined.

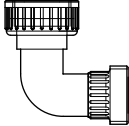
Type	Threaded connection size		Body material	Product number
	Internal and external thread			
 TM06 8129 4716	G 5/4"		PVC	99168768

Wall or tank mounting assembly for SMART Digital XL DDA/DDE

The prefabricated outlet-side assembly for wall or tank mounting of SMART Digital XL DDA and DDE pumps includes:

- Bracket with screws and washers for wall-mounting or tank installation of SMART Digital XL
 - Suitable tank sizes 200 l, 300 l, 500 l and 1000 l
- Pressure loading valve PLV, preset to 3 bar opening pressure (adjustable to up to 10 bar)
- Pressure relief valve PRV, preset to 6 bar opening pressure (adjustable to up to 10 bar)
- Pulsation damper DBG with a volume of 0.35 l, with pressure gauge, pre-charged to 2.7 bar (pre-chargeable to up to 8 bar)
- Optionally without pulsation damper
 - For installation with rigid pipes, the pump must be limited to 50 % of its maximum dosing capacity.
 - For installation with hoses, the pump must be limited to 75 % of its maximum dosing capacity.

Dimensions

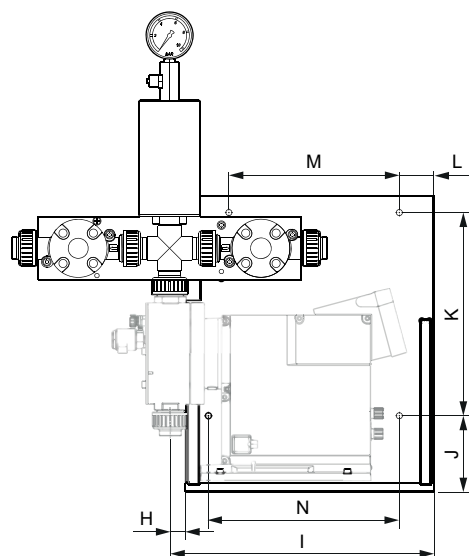

TM06 8419 0517

Fig. 62 Side view, wall or tank mounting assembly

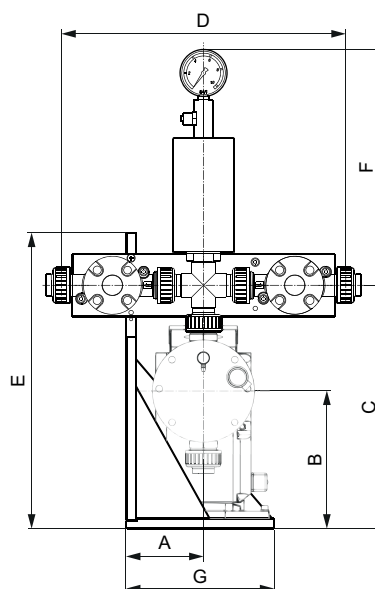

TM06 8420 0517

Fig. 63 Back view, wall or tank mounting assembly

SMART digital XL DDA/DDE				
		60-10	120-7	200-4
A	[mm]	117	117	117
B	[mm]	203	203	203
C	[mm]	332.5	348	358
D	[mm]	410	410	410
E	[mm]	435	435	435
F	[mm]	346.5	346.5	346.5
G	[mm]	218	218	218
H	[mm]	20	20	20
I	[mm]	385	385	385
J	[mm]	112	112	112
K	[mm]	298	298	298
L	[mm]	51	51	51
M	[mm]	234	234	234
N	[mm]	280	280	280

Technical data

Variant	Materials		Product number
	Body	Gaskets	
With pulsation damper	PVC	FKM	99211372
		EPDM	99211483
Without pulsation damper	PVC	FKM	99211484
		EPDM	99211485

Tank accessories

Adapter plates for tank mounting

- Made of black HD-PE, including stainless-steel screws and washers

Applica- tion	For pump type	Tank size [l]	Contents	Product number
2 pumps on 1 tank	SMART S DDA/ DDC/DDE / DMX 221 / DDI	60-500	1 adapter plate, 12 screws, 12 washers	98982080
1 pump on 1 tank	DMX 226 or DMH 251/252/ 253	200-500	1 adapter plate, 8 screws, 8 washers	99211241

Wall brackets

- For assembly of one of the mentioned pump types
- With installation material for wall mounting and pump mounting

For pump type	Material	Product number
DMX 221, DDI 222	PP	91836471
DMX 226, DMH 251-253, DME 60-10 / 150-4, SMART Digital XL DDA/DDE	PE	99211245

11. Pumped liquids

The resistance table below is intended as a general guide for material resistance (at room temperature), and does not replace testing of the chemicals and pump materials under specific working conditions.

The data shown are based on information from various sources available, but many factors (purity, temperature etc.) may affect the chemical resistance of a given material.

Note: Some of the liquids in this table may be toxic, corrosive or hazardous. Please be careful when handling these liquids.

Pumped liquid (20 °C)			Material							
			Dosing head			Gasket			Ball	PE (Accessories)
Description	Chemical formula	Concentration %	PVC	PVDF	SS 1.4401	FKM	EPDM	PTFE	Ceramic	
Acetic acid	CH ₃ COOH	25	•	•	•	-	•	•	•	•
		60	•	•	•	-	•	•	•	•
		85	-	•	○	-	-	•	•	-
Aluminium chloride	AlCl ₃	40	•	•	-	•	•	•	•	•
Aluminium sulphate	Al ₂ (SO ₄) ₃	60	•	•	•	•	•	•	•	•
Ammonia, aqueous	NH ₄ OH	28	•	-	•	-	•	•	•	•
Calcium hydroxide ¹⁾	Ca(OH) ₂		•	•	•	•	•	•	•	•
Calcium hypochlorite	Ca(OCl) ₂	20	•	•	-	•	•	•	•	•
		10	•	•	-	•	•	•	•	•
		30	•	•	-	•	○	•	•	•
Chromic acid	H ₂ CrO ₄	50	•	•	-	•	-	•	•	•
Copper sulphate	CuSO ₄	30	•	•	•	•	•	•	•	•
Ferric chloride ²⁾	FeCl ₃	60	•	•	-	•	•	•	•	•
Ferric sulphate ²⁾	Fe ₂ (SO ₄) ₃	60	•	•	○	•	•	•	•	•
Ferrous chloride	FeCl ₂	40	•	•	-	•	•	•	•	•
Ferrous sulphate	FeSO ₄	50	•	•	•	•	•	•	•	•
Fluosilicic acid	H ₂ SiF ₆	40	•	•	○	-	○	•	•	•
Hydrochloric acid	HCl	< 25	•	•	-	•	•	•	•	•
		25-37	•	•	-	•	○	•	•	•
Hydrogen peroxide	H ₂ O ₂	30	•	•	•	•	•	•	•	•
		30	•	•	•	•	•	•	•	•
Nitric acid	HNO ₃	40	•	•	•	•	-	•	•	•
		70	-	•	•	•	-	•	•	○
Peracetic acid	CH ₃ COOOH	5-15	○	•	○	-	-	•	•	○
Potassium hydroxide	KOH	50	•	-	•	-	•	•	•	•
Potassium permanganate	KMnO ₄	10	•	•	•	○	•	•	•	•
Sodium chlorate	NaClO ₃	30	•	•	•	•	•	•	•	•
Sodium chloride	NaCl	30	•	•	-	•	•	•	•	•
Sodium chlorite	NaClO ₂	20	○	•	-	•	•	•	•	•
Sodium hydroxide	NaOH	30	•	•	•	○	•	•	•	•
		50	•	•	•	-	•	•	•	•
Sodium hypochlorite	NaClO	12-15	•	•	-	•	•	•	•	•
Sodium sulphide	Na ₂ S	30	•	•	•	•	•	•	•	•
Sodium sulphite	Na ₂ SO ₃	20	•	•	•	•	•	•	•	•
Sodium thiosulfate	Na ₂ S ₂ O ₃	10	•	•	•	•	•	•	•	•
Sulphurous acid	H ₂ SO ₃	6	•	•	•	•	•	•	•	•
		< 80	•	•	-	•	○	•	•	•
		80-96	•	•	-	•	-	•	•	-
Sulphuric acid ³⁾	H ₂ SO ₄	98	-	•	•	○	-	•	•	-

• Resistant

○ Limited resistance

- Not resistant

1) Once the pump is stopped, calcium hydroxide will sediment rapidly.

2) Risk of crystallisation.

3) Reacts violently with water and generates much heat.
(Pump should be absolutely dry before dosing sulphuric acid.)

Further information:

<http://product-selection.grundfos.com/liquids.html>

12. Grundfos Product Center

Online search and sizing tool to help you make the right choice.

<http://product-selection.grundfos.com>



"SIZING" enables you to size a pump based on entered data and selection choices.

"REPLACEMENT" enables you to find a replacement product. Search results will include information on the following:

- the lowest purchase price
- the lowest energy consumption
- the lowest total life cycle cost.

The screenshot shows the website's navigation bar with 'HOME', 'FIND PRODUCT', 'COMPARE', 'YOUR PROJECTS', 'SAVED ITEMS', and 'HELP'. Below is a search bar with a 'SEARCH' button. A row of four main navigation buttons is visible: 'SIZING' (Enter pump sizing), 'CATALOGUE' (Products and services), 'REPLACEMENT' (Replace an old pump with a new), and 'LIQUIDS' (Find pump by liquid). The 'QUICK SIZING' section includes input fields for 'Flow (Q)*' (m³/h) and 'Head (H)*' (m), radio buttons for 'Select what to size by' (application, pump design, pump family), and a 'START SIZING' button. At the bottom, there are 'ADVANCED SIZING' options for 'Advanced sizing by application' and 'Guided selection'.

"CATALOGUE" gives you access to the Grundfos product catalogue.

"LIQUIDS" enables you to find pumps designed for aggressive, flammable or other special liquids.

All the information you need in one place

Performance curves, technical specifications, pictures, dimensional drawings, motor curves, wiring diagrams, spare parts, service kits, 3D drawings, documents, system parts. The Product Center displays any recent and saved items - including complete projects - right on the main page.

Downloads

On the product pages, you can download installation and operating instructions, data booklets, service instructions, etc. in PDF format.

Subject to alterations.

be think innovate

99021865 0217

ECM: 1174377

GRUNDFOS A/S
DK-8850 Bjerringbro . Denmark
Telephone: +45 87 50 14 00
www.grundfos.com

GRUNDFOS 

The name Grundfos, the Grundfos logo, and be think innovate are registered trademarks owned by Grundfos Holding A/S or Grundfos A/S, Denmark. All rights reserved worldwide. © Copyright Grundfos Holding A/S